

Product Description

Options for Moduflex-series

M0741-1

Tool changers | Swivels | Swivels with Tool changers | Grippers | Hose packages | Valve Units | Tool systems

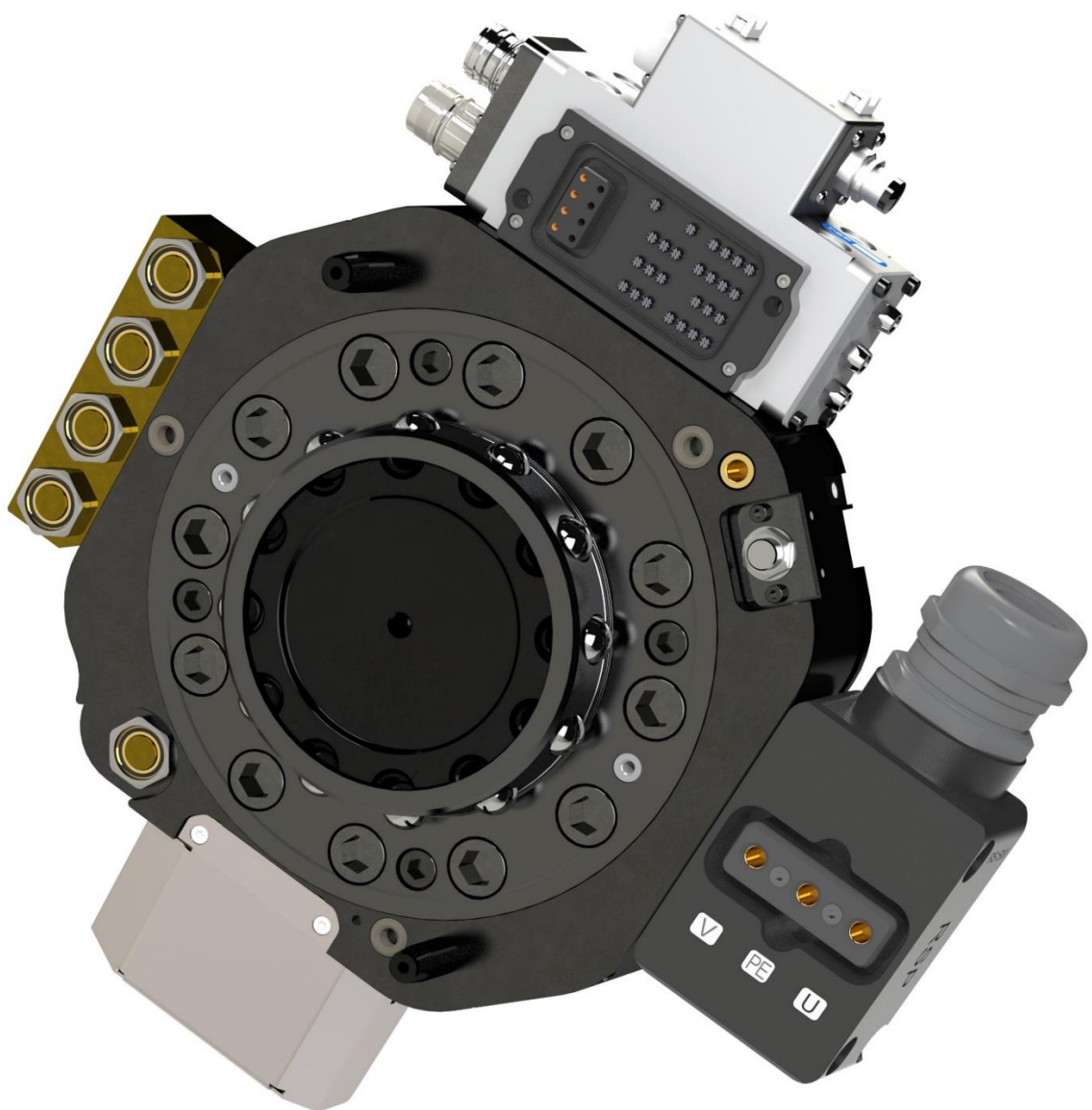

The information in this document is subject to change without prior notice and should not be regarded as an undertaking from Robot System Products AB. Robot System Products AB assumes no responsibility for errors that may occur in this document.

Robot System Products AB bears no responsibility for damage that is incurred by the use of this document, or the software or hardware described in this document.

The document, or parts of it, may not be reproduced or copied without prior permission from Robot System Products AB. It may neither be imparted to a third party, nor otherwise be used without authorization. Infringement hereof will be subject to action in accordance with the applicable laws.

Further copies of this document can be obtained from Robot System Products AB at current prices.

© Robot System Products AB

Robot Systems Products AB
Kokillgatan 9
SE-721 33 Västerås
Sweden

CONTENTS

1 INTRODUCTION	8
1.1 RSP tool changers	9
1.2 Documents	9
1.3 Wear parts.....	9
1.4 Complementary equipment from RSP	9
2 TECHNICAL SPECIFICATIONS.....	10
2.1 Placement of options on tool changers Type A.....	11
2.2 Placement of options on tool changers Type B.....	12
2.3 Placement of options on tool changers Type C.....	13
3 VALVES AND SENSORS	14
3.1 Integrated valve, TC Open/Close. Article: P6718.....	14
3.2 Integrated valve, TC Open/Close. Articles: P7710 and P7710-4.....	15
3.3 Valve adapter (external valve). Article: P7084	16
3.4 Magnetic sensors TC Opened/TC Closed.	17
3.5 Tool in stand sensor, active. Articles: P8528	18
3.6 Tool in stand sensor, passive side. Article: P8369.....	18
3.6.1 Circuit diagram, E0186-129 for P8528	19
3.7 Analog pressure sensor. Article: P7257A	20
3.7.1 Circuit diagram, E0203-377 for P7257A	21
3.8 TC Empty sensor. Article: P7145-1.....	22
3.8.1 Circuit diagram, E0203-078 for P7145-1.....	23
3.9 TC Empty sensor, mechanical, robot side, Article: P7288	24
3.10 TA Empty sensor receptor, tool side. Article: P7327	24
3.10.1 Circuit diagram, E0230-618 for P7288.....	25
4 ADAPTATION KITS FOR SIGNAL MODULES	26
4.1 Adaptation kit for Large and Small modules, Type C. Article: P7246	27
4.2 Adaptation kit for Large and Small signal modules, TC side. Article: P7323	28
4.3 Adaptation kit for Large and Small signal modules, TA side. Article: P7324	28
4.4 Adaptation kit for two Small power modules, TC side. Article: P7315	29
4.5 Adaptation kit for two Small power modules, TA side. Article: P7316	29
5 SMALL SIGNAL MODULES.....	30
5.1 Signal module 17x, robot side. Article: P6738-1	30
5.1.1 Circuit diagram E0178-246 for P6738-1.....	31
5.2 Signal module 17x, tool side, Article: P6739.....	32
5.2.1 Circuit diagram E0178-247 for P6739.....	33
5.3 Signal module 19x, robot side. Article: P7224	34
5.3.1 Circuit diagram E0178-764 for P7224.....	35

5.4 Signal module 19x, tool side, Article: P7225.....	36
5.4.1 Circuit diagram E0178-765 for P7225.....	37
5.5 Signal module 23x, robot side. Article: P6711	38
5.5.1 Circuit diagram E0178-207 for P6711.....	39
5.6 Signal module 23x, tool side, Article: P6721.....	40
5.6.1 Circuit diagram E0178-208 for P6721.....	41
5.7 Bus module, Profinet, robot side. Article: P6771.....	42
5.7.1 Circuit diagram E0178-317 for P6771.....	43
5.8 Bus module, Profinet, tool side, Article: P6775.....	44
5.8.1 Circuit diagram E0178-320 for P6775.....	45
5.9 Contact cover for Small signal modules, tool side. Article: P7262.....	46
6 SMALL POWER MODULES	47
6.1 Power module M23, robot side. Article: P6768-2.....	47
6.1.1 Circuit diagram E0178-314 for P6768-2.....	48
6.2 Power module M23, tool side, Article: P6772-2	49
6.2.1 Circuit diagram E0178-321 for P6772-2.....	50
6.3 Contact cover for Small power modules, tool side. Article: P7263	51
7 LARGE MODULES	52
7.1 Multi-module with Profinet, robot side. Article: P6778.....	52
7.1.1 Circuit diagram E0230-290 for P6778.....	53
7.2 Multi-module with Profinet, tool side. Article: P6779	55
7.2.1 Circuit diagram E0230-291 for P6779.....	56
7.3 Signal and bus module, robot side. Article: P6780	57
7.3.1 Circuit diagram E0230-292 for P6780.....	58
7.4 Signal and bus module, tool side. Article: P6781	60
7.4.1 Circuit diagram E0230-293 for P6781.....	61
7.5 Signal and power module (ABB compatible), robot side. Article: P7291	62
7.5.1 Circuit diagram E0178-862 for P7291 and P7292	63
7.6 Signal and power module (ABB compatible), tool side. Article: P7292.....	66
7.7 Signal and power module (Yaskawa compatible), robot side. Article: P7289.....	67
7.7.1 Circuit diagram E0178-860 for P7289 and P7290	68
7.8 Signal and power module (Yaskawa compatible), tool side. Article: P7290	71
7.9 Power TC module 8s, base, robot side. Article: P7325.....	72
7.10 Power TA module 8p, base, tool side. Article: P7326	73
7.11 Large module contact cover, tool side. Article: P7249	74
8 WATER AND AIR MODULES	75
8.1 Water/air coupling, 1–4 channels, robot side. Article: P7318.....	75
8.1.1 Pneumatic diagram, Pne0230-017.....	76
8.1.2 Configuration of couplings, A0230-627	77
8.2 Water/air coupling, 1–4 channels, tool side. Article: P7319	78
8.2.1 Configuration of couplings, A0230-628	79
8.3 Air coupling, 8 channels, robot side. Article: P6847	80
8.4 Air coupling, 8 channels, tool side. Article: P6848	81

9 WELD POWER MODULES.....	82
9.1 Weld power connector M40, robot side. Article: P6716.....	82
9.2 Weld power connector M50, robot side. Article: P6784.....	83
9.3 Weld power connector, MC connector, robot side. Article: P6717.....	84
9.4 Weld power connector with RobiFix, robot side. Article: P6794	85
9.5 Weld power connector with cable gland, tool side. Article: P6726	86
9.6 Weld power connector with 3 cables, tool side. Article: P1517	87
9.7 Weld power connector 2 x M40, robot side. Article: P6766.....	88
9.8 Weld power connector with 2 x cable gland, tool side. Article: P6767.....	89
9.9 Weld power connector with 2 x RobiFix, robot side. Article: P7336.....	90
9.10 Weld power connector 6 x cable gland, tool side. Article: P7337	91
9.11 Weld power connector cover, tool side. Article: P6742	92
10 SAFETY SIGNAL MODULES. ARTICLE: P7501-XXX.....	93
10.1 Safety module, MH, robot side (ABB compatible): P7501-075.....	94
10.2 Safety module, MH, tool side (ABB compatible): P7501-074	94
10.3 Safety module, SWS, robot side (ABB compatible): P7501-072	95
10.4 Safety module, SWS, tool side (ABB compatible): P7501-073.....	95
10.5 Safety module, MH, robot side (KUKA compatible): P7501-076	96
10.6 Safety module, MH, tool side (KUKA compatible): P7501-077.....	96
10.7 Safety module, SWS, robot side (KUKA compatible): P7501-078.....	97
10.8 Safety module, SWS, tool side (KUKA compatible): P7501-079	97
10.9 Safety module, MH, robot side (Yaskawa compatible): P7501-823.....	98
10.10 Safety module, MH, tool side (Yaskawa compatible): P7501-824.....	98
11 OTHER MODULES	99
11.1 Programming tool for TC480. Articles: P7160 and P7162.....	99
11.2 Programming tool for TA480. Articles: P7161 and P7163.....	99
11.3 TC ground socket. Article: P7239	100
11.4 TA ground socket. Article: P7147	100
11.5 Pressure booster kit. Article: P8213-1	101
11.6 Forced opening kit. Article: P6910.....	101
11.7 Robot adaptation kits.....	102
11.8 Limitation of Robot movements	102
11.9 Tool Identification	102
12 SPARE PARTS	103
12.1 Tool changer side.....	103
12.1.1 Parts list for integrated valve, P6718	103
12.1.2 Parts list for integrated valve, P7710 and P7710-4.....	104
12.1.3 Parts list for valve adapter, P7084	104
12.1.4 Parts list for magnetic sensors, P6789, P6873-2.....	105
12.1.5 Parts list for magnetic sensors P7172, P7173, P7174, P7293 and P7175.....	105
12.1.6 Parts list for tool in stand sensor, active. P8528	106
12.1.7 Parts list for signal interface, P6738-1, P7224, P6711 and P6771	106

12.1.8	Parts list for servo interface M23, P6768-2.....	107
12.1.9	Parts list for signal interface, P6778, P6780, P7291 and P7289	107
12.1.10	Parts list for signal interface P7325.....	108
12.1.11	Parts list for water/air coupling, P7318.....	108
12.1.12	Parts list for air coupling, P6847	109
12.1.13	Parts list for weld power connector, P6716, P6784, P6717 and P6794	109
12.1.14	Parts list for weld power connector, P6766.....	110
12.1.15	Parts list for weld power connector, P7336.....	111
12.1.16	Parts list for forced opening kit, P6910	112
12.2	Tool attachment side	113
12.2.1	Parts list for signal interface, P6739, P7225, P6721 and P6775	113
12.2.2	Parts list for power interface M23, P6772-2.....	113
12.2.3	Parts list for signal interface, P6779, P6781, P7292 and P7290	114
12.2.4	Parts list for water/air coupling, P7319.....	115
12.2.5	Parts list for air coupling, P6848	115
12.2.6	Parts list for weld power connector, P6726.....	116

1 INTRODUCTION

Robot System Products is a front-rank provider of peripheral products for high performance robot applications. We provide complete system solutions for your robot installations, aiming to improve your productivity with the most reliable and cost-effective tooling on the market. Continuously we explore emerging technologies, working with leading edge design.

Robot System Products has a wide range of standard robot peripheral products:

- Tool changers
- Swivels
- Swivel tool changers
- CiRo
- Grippers
- Hose Packages
- Valve units
- Tool systems
- Tool parking systems

Robot System Products' tool changers are constructed to maximize the flexibility and reliability of your robot fleet. Through our patented locking device TrueConnect™ robustness and high safety are combined with low weight and compactness. With our swivels compressed air, water, electrical and data signals as well as weld and servo power are transferred to your tools with robot motion capabilities fully maintained. Our swivel tool changers unite the TrueConnect™ mechanism with our swivel technology, combining the best out of the two technologies. With RSP's cost-effective CiRo, cables and hoses can be freely selected with high robot flexibility maintained, and space requirements reduced. Our integrated tool systems are delivered as complete plug-and-play solutions designed for quick and simple installation.

Robot System Products' product lines are available for all major robot brands and come with complete documentation. 3D-models for simulation are available for download at: robotssystemproducts.com.



1.1 RSP tool changers

The Robot System Products' tool changers enable robots to handle and switch between multiple tools. They are built to ensure reliable and smooth operation, being compact with low weight and robust design and incorporating many safety features. Depending on model and options, electrical signals, weld and servo power, data, water and compressed air are transferred from the robot side to the tool.

The patented locking device TrueConnect™ has a minimum of play and gives a practically, through the lifespan, absolute positioning repeatability. The principle behind the locking mechanism is that load is uniformly distributed by pressing locking balls into spherical cavities. In consequence, substantially larger positional tolerances are accepted during docking. A built-in spring ensures that the tool remains in place in the tool changer even if the air pressure drops.

1.2 Documents

This *Product Description* (M0741-1) contains product information, drawings, data, electrical and pneumatic diagrams and lists of spare parts for options to the Moduflex-series tool changers and tool attachments. The tool changers and tool attachments are described in *Product Description Tool changers Moduflex-series* (M0742-1). The corresponding information for Moduflex tool changers prepared for direct mounting of Safety signal modules are found in *Product Description Prepared for Safety* (M0740-1). The utilization and functionality of the RSP Safety signal module, P7501-XXX are described in the manual M8353-1. In the document *Installation and Maintenance* (M0720-1) procedures for mounting, installation, replacement of equipment are described together with maintenance activities and intervals. In the *Product Manual Tool parking system TPS 400* (M8311-1) complete systems for parking of tool attachment and tools are described.

1.3 Wear parts

Wear parts should be replaced before considerable damage occurs. The interval depends on the number of tool changes and its working environment. Generally, the more contaminated environment, the closer maintenance intervals. The following parts are considered as wear parts:

- Water/air couplings
- Signal pins
- Servo and weld power pins and sockets
- Guide pins and bushings
- Air sealings

1.4 Complementary equipment from RSP

Complementary equipment is described in separate documents.

Article	Note
External valve units	Mounted at the rear of the upper arm. Shuts off air automatically during tool change.
Cable and hose packages	Complete packages for most robots on the market ready to be mounted without any modifications.
Tool parking systems	RSP tool parking systems give rigid installations for easy tool changing.
Connection kits	Connection kits for tool changers and tool attachments simplifying electrical installations.
3D-models	Available in Solid Works®, STEP and Parasolid-format.

2 TECHNICAL SPECIFICATIONS

This document presents modules for electrical signals, weld and servo power, data, water and compressed air, which can be mounted and connected to the tool changers and tool attachments of the RSP product family Moduflex. The options can be combined in different configurations which are generally useable within the entire product family and be used in a broad spectra of applications.

Depending on which positions different types of options can be placed, and the possible need of adaptation kits, the Moduflex family is divided into three different groups.

Placement type	Tool changer model	Corresponding tool attachments
Type A	P7330 (TC240)	P7331 (TA240)
	P7332 and P7334 (TC480)	P7333 and P7335 (TA480)
Type B	P7722 (TC240)	P7723 (TA240)
	P7834 and P7836 (TC480)	P7835 and P7837 (TA480)
Type C	P6958 and P6960 (TC720)	P6959 and P6961 (TA720)
	P7924 and P7924-1 (TC960-1)	P7925 (TA960)



NOTE! Types B and C are prepared for RSP Safety signal modules and are described as parts in *Product Description Tool changers Prepared for Safety* (M0740-1),



NOTE! Types A and C are described in the manual *Product Description Tool changers Moduflex-series* (M0742-1) .

The figure below is an example that shows a configuration for spot welding, typical of types B and C.



TC480-SWS

2.1 Placement of options on tool changers Type A

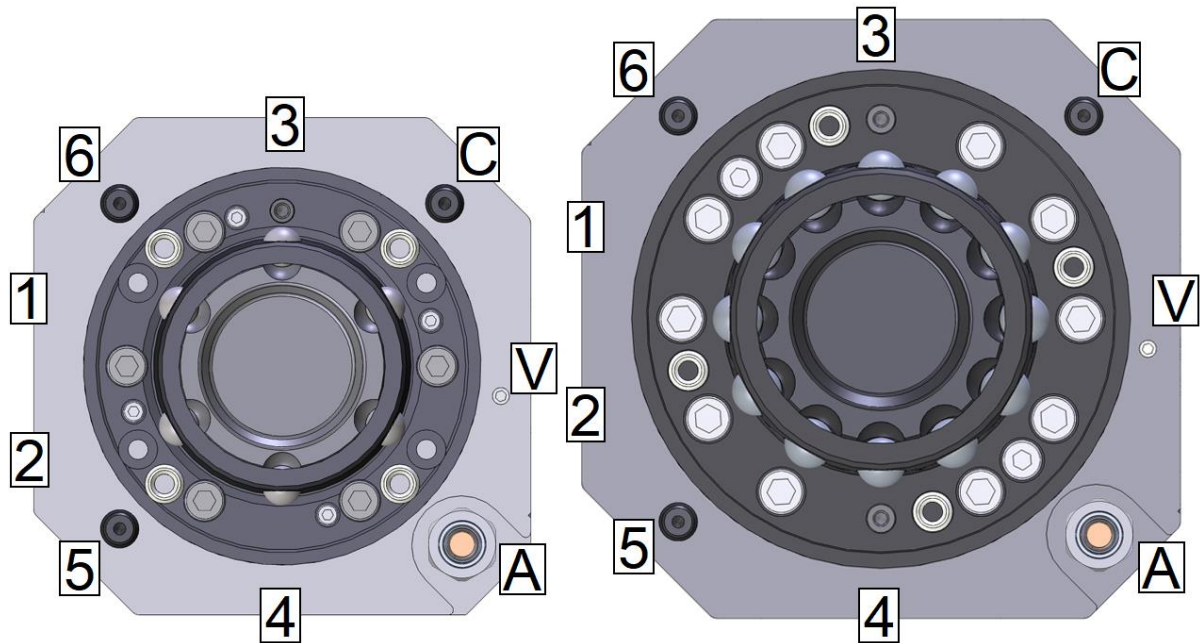

For tool changers Type A options are placed as follows:

	Position			
	1	2	3 and 4 (each)	5 and 6 (each)
Small signal modules	1 module, direct mounting	1 module, direct mounting	2 modules, with P7323	1 module, direct mounting
Small power modules	1 module, direct mounting	1 module, direct mounting	2 modules, with P7315	1 module, direct mounting
Large modules	1 module, direct mounting		1 module, with P7323	N.A.
Water/air modules	N.A.		1 module, direct mounting	N.A.
Weld power modules	N.A.		1 module, direct mounting	N.A.

- An Integrated valve (P6718) can be mounted in position V.
- A Magnetic sensor TC Opened/TC Closed (P6789, P7173) can be mounted in position C.
- Pneumatic air shall be connected in position A.



NOTE! There may be additional restrictions on mounting positions depending on size and form of modules and configuration of cables, hoses and connections.

2.2 Placement of options on tool changers Type B

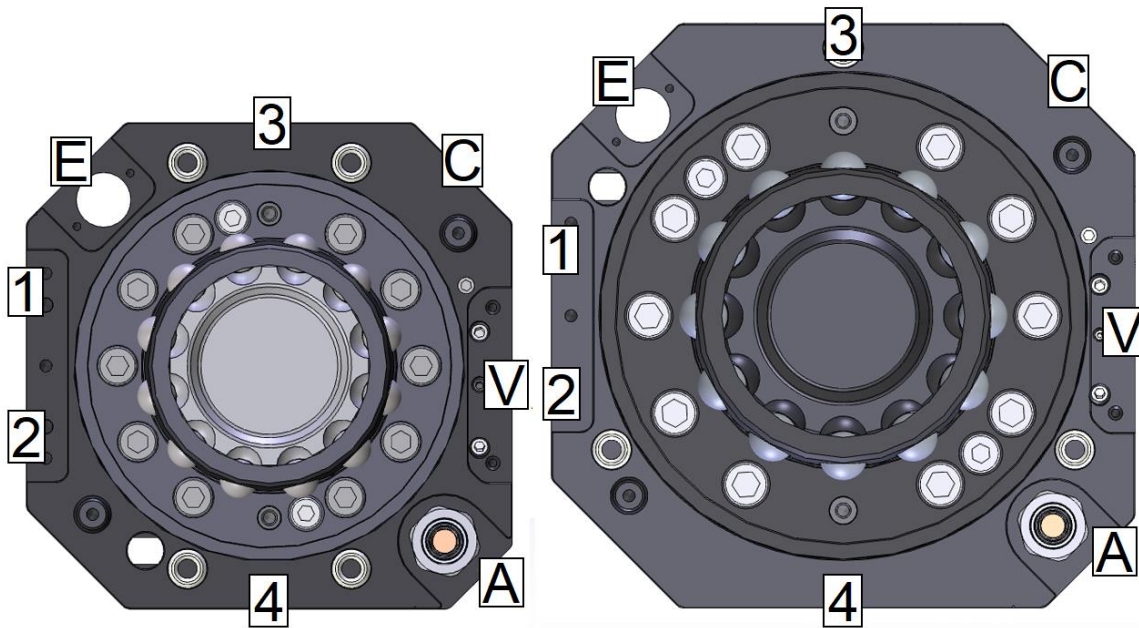

For tool changers Type B options are placed as follows:

	Position			
	1	2	3	4
Small signal modules	N.A.	N.A.	2 modules, with P7323	2 modules, with P7323
Small power modules	N.A.	N.A.	2 modules, with P7315	2 modules, with P7315
Large modules	N.A.		1 module, with P7323	1 module, with P7323
Water/air modules	N.A.		1 module, direct mounting	1 module, direct mounting
Weld power modules	N.A.		1 module, direct mounting	1 module, direct mounting
Safety modules	1 module, direct mounting		N.A.	N.A.

- An Integrated valve (P7710, P7710-4) can be mounted in position V.
- A Magnetic sensor TC Opened/TC Closed (P6789, P7173) can be mounted in position C.
- A TC Empty sensor (P7145-1) can be mounted in position E.
- Pneumatic air shall be connected in position A.



NOTE! There may be additional restrictions on mounting positions depending on size and form of modules and configuration of cables, hoses and connections.

2.3 Placement of options on tool changers Type C

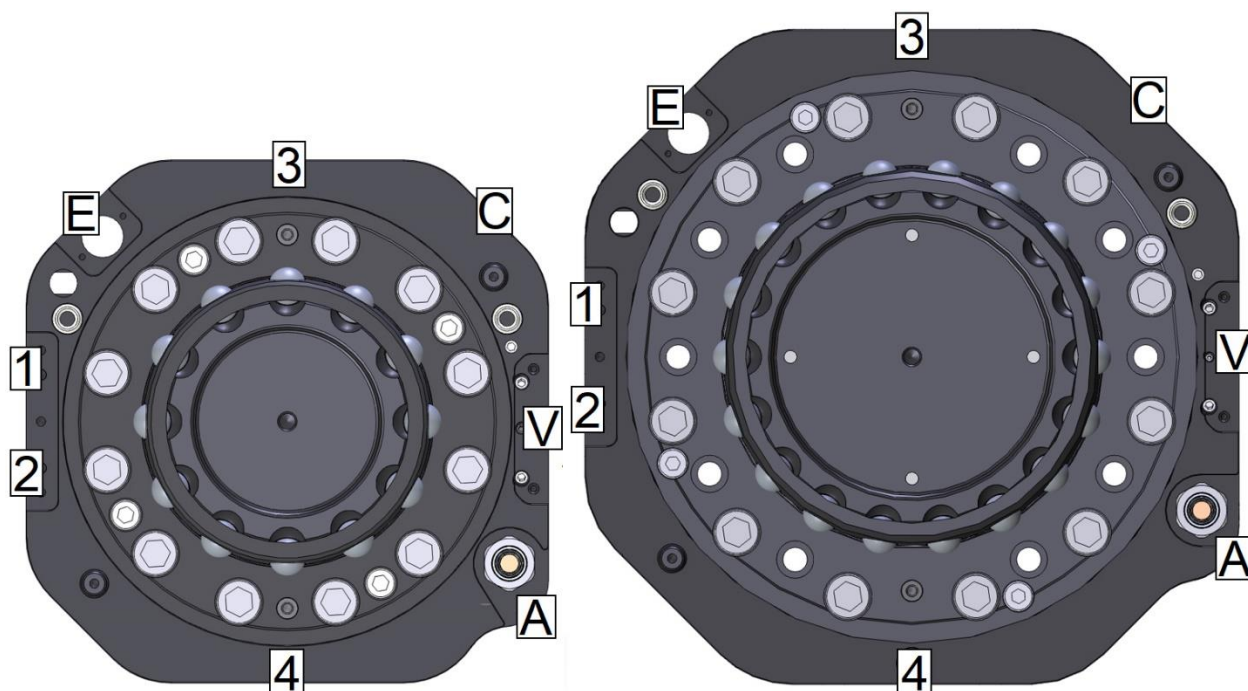

For tool changers Type C options are placed as follows:

	Position			
	1	2	3	4
Small signal modules	2 modules with P7246	1 module, direct mounting or 2 modules, with P7323	1 module, direct mounting or 2 modules, with P7323	1 module, direct mounting or 2 modules, with P7323
Small power modules	1 module with P7246	1 module, direct mounting or 2 modules, with P7315	1 module, direct mounting or 2 modules, with P7315	1 module, direct mounting or 2 modules, with P7315
Large modules	1 module with P7246	1 module, with P7323	1 module, with P7323	1 module, with P7323
Water/air modules	N.A.	1 module, direct mounting	1 module, direct mounting	1 module, direct mounting
Weld power modules	N.A.	1 module, direct mounting	1 module, direct mounting	1 module, direct mounting
Safety modules	1 module, direct mounting	N.A.	N.A.	N.A.

- An Integrated valve (P7710, P7710-4) can be mounted in position V.
- A Magnetic sensor TC Opened/TC Closed (P7174, P7293, P7175) can be mounted in position C.
- A TC Empty sensor (P7145-1) can be mounted in position E.
- Pneumatic air shall be connected in position A.



NOTE! There may be additional restrictions on mounting positions depending on size and form of modules and configuration of cables, hoses and connections.

3 VALVES AND SENSORS

3.1 Integrated valve, TC Open/Close. Article: P6718

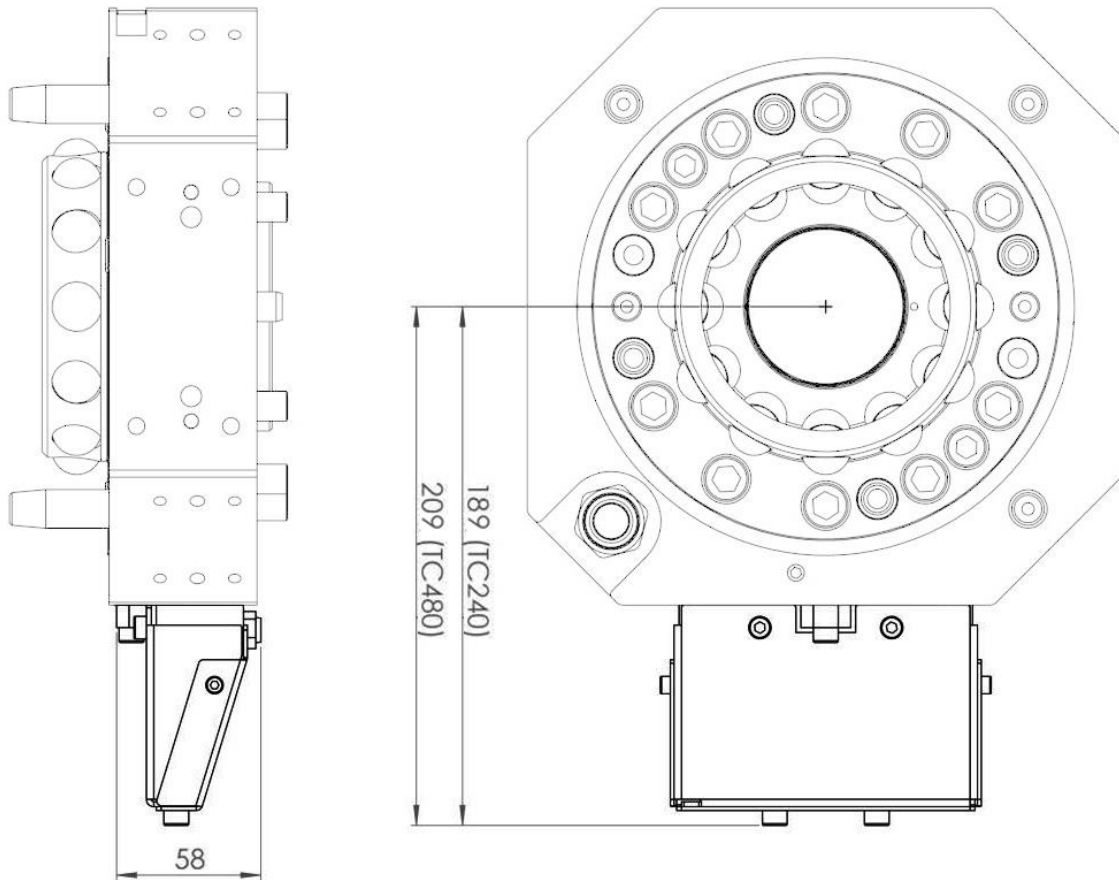

Includes two integrated valves. The TC Close valve is in passive position open, which is locking the tool changer. The TC Open valve is in passive position evacuating the air from the unlocking side of the piston inside the tool changer, which is allowing the tool to be locked.

In order to Open (unlock) the tool changer, the signals “doOpen TC 1” and “doOpen TC 2” shall both be set to +24V DC. If one or both of the electrical signals disappear the tool changer will go to closed (locked) position. Air is supplied via “Air in” on the tool changer.

To be mounted at one dedicated position on tool changers Type A.



NOTE!

Are prepared for options P6738-1, P7224, P6778, P6780, P7291 and P7289,

Technical data

Weight		0.5 kg
Electrical signals	Circuit diagram Dedicated signals Connection	See respective signal module. doOpen TC 1, doOpen TC 2, 0V DC M8 3p
Air channels	Pneumatic diagram Air supply Air quality	Pne0230-017 (section 8.1.1) Air in marked “AIR” on TC (6-10 bar) Oil-clean and waterless filtered air, with max 25µm particle content

3.2 Integrated valve, TC Open/Close. Articles: P7710 and P7710-4

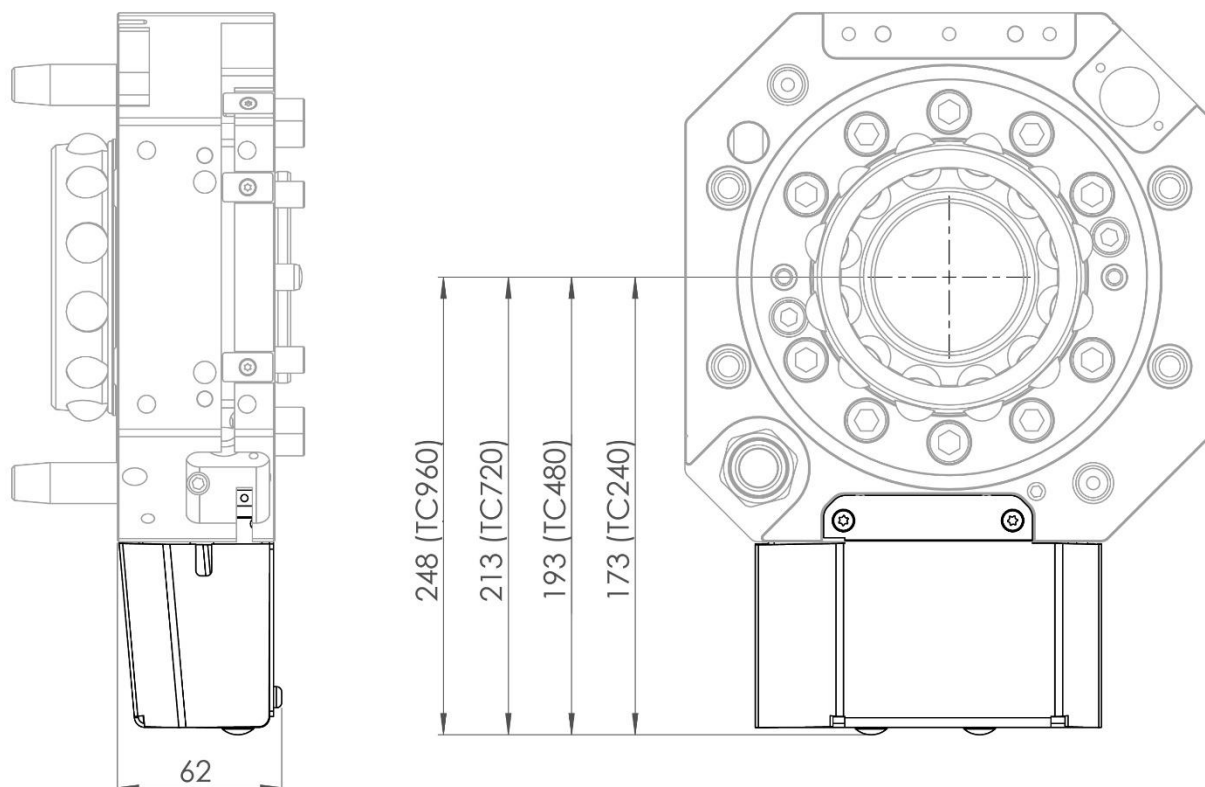

Includes two integrated valves. The TC Close valve is in passive position open, which is locking the tool changer. The TC Open valve is in passive position evacuating the air from the unlocking side of the piston inside the tool changer, which is allowing the tool to be locked.

In order to Open (unlock) the tool changer, the signals “doOpen TC 1” and “doOpen TC 2” shall both be set to +24V DC. If one or both of the electrical signals disappear the tool changer will go to closed (locked) position. Air is supplied via “Air in” on the tool changer.

To be mounted at one dedicated position on tool changers Type B and C.



NOTE!

P7710 is prepared for options P6738-1, P7224, P6778, P6780, P7291 and P7289.



NOTE!

When RSP Safety signal module, P7501-XXX is used P7710-4 shall be selected.

Technical data

Weight		0.3 kg
Electrical signals	Circuit diagram	See respective signal module.
	Dedicated signals	doOpen TC 1, doOpen TC 2, 0V DC
	Connection P7710	M8 3p
	Connection P7710-4	M8 4p
Air channels	Pneumatic diagram	Pne0230-017 (section 8.1.1)
	Air supply	Air in marked “AIR” on TC (6-10 bar)
	Air quality	Oil-clean and waterless filtered air, with max 25µm particle content

3.3 Valve adapter (external valve). Article: P7084

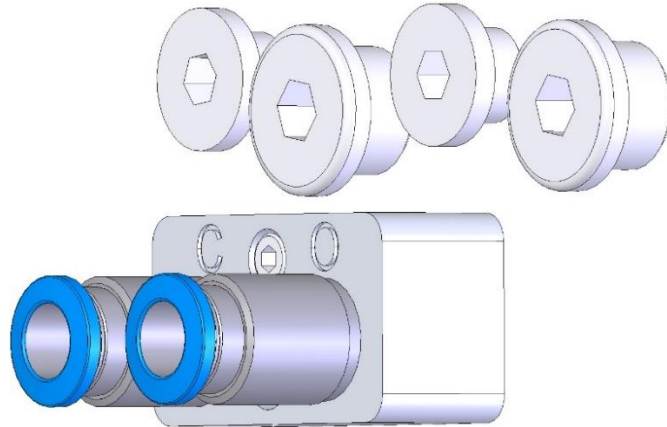

To be used for connecting external valves to tool changer when integrated valve. Includes blind plugs for covering connections to the integrated valve and sensors on the tool changer when they are not in use.

To be mounted at position **V** on tool changers Type B and Type C.



NOTE!

To be used when Integrated valve P7710/P7710-4 is not mounted at position **V**.

Technical data

Weight		0.1 kg
Air channels	Pneumatic diagram	Pne0230-017 (section 8.1.1)
	Dedicated channels, 8 mm hose	Open TC marked O (6–10 bar) Close TC marked C (6–10 bar)
	Air quality	Oil-clean and waterless filtered air, with max 25µm particle content

3.4 Magnetic sensors TC Opened/TC Closed.

Articles: P6789, P7172, P6873-2, P7173, P7174, P7293 and P7175

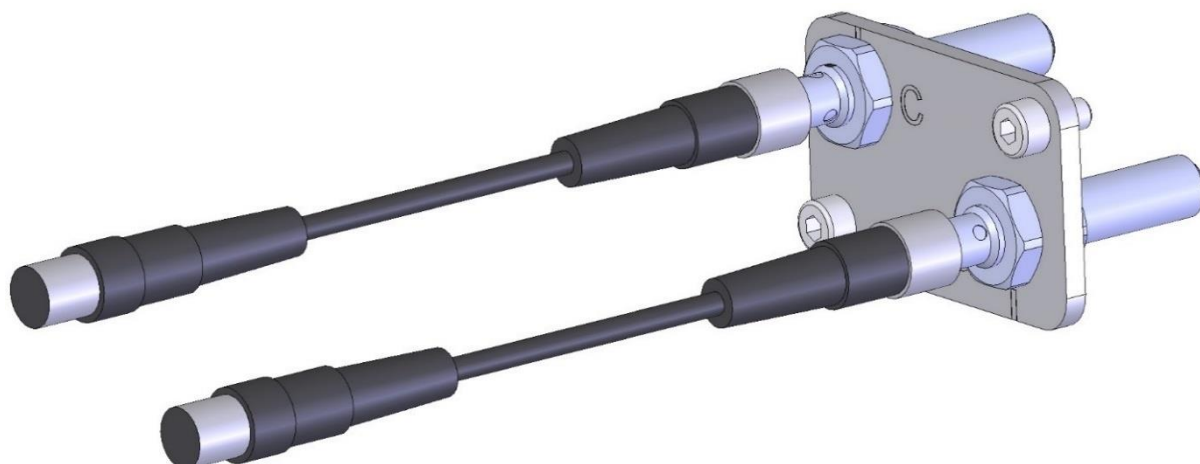

One magnetic sensor which gives +24V signal “TC Opened” when tool changer is unlocked and one magnetic sensor which gives +24V signal “TC Closed” when tool changer is locked. To be mounted at position **C** on the tool changer.



NOTE!

Are prepared for options P6738-1, P7224, P6778. P6780, P7291, P7289 and P7501-XXX (TC-side).



NOTE!

The magnetic sensors are each dedicated for a specific tool changer (see below).

Technical data

Weight		0.05 kg
Electrical signals	Circuit diagram	See respective signal module.
	Dedicated signals	0V DC, 24V DC TC Closed (24V DC), TC Opened (24V DC)
	Connections	2 x M8 3P

Magnetic sensor	Tool changers
P6789	P7330 (TC240)
P7172	P7722 (TC240)
P6873-2	P7332, P7334 (TC480)
P7173	P7834, P7836 (TC480)
P7174	P6958 (TC720-1)
P7293	P6960 (TC720-1)
P7175	P7924, P7924-1 (TC960-1)

3.5 Tool in stand sensor, active. Articles: P8528



Active RFID sensor, which gives +24V signals “Tool_In_Stand1” and “Tool_In_Stand2” when tool is positioned in tool stand. To be mounted at one dedicated position on the tool attachment and combined with passive sensor P8369 mounted on a dedicated position on the tool stand.

Weight		0.05 kg
Electrical signals	Circuit diagram	E0186-129 (section 3.6.1)
	M8 8P (0,2 m cable)	Tool_In_Stand1, Tool_In_Stand2, 0V, 24V

3.6 Tool in stand sensor, passive side. Article: P8369

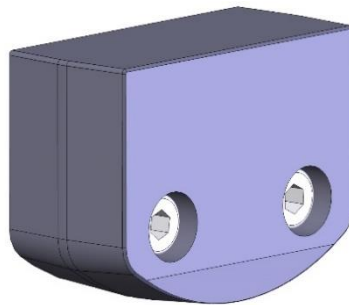

Passive tool-in-stand sensor P8369 to be used together with active tool in stand sensor P8528 for checking that the tool/tool attachment is present in the parking position before the tool changer is permitted to open.

Technical data

Weight	0.02 kg
---------------	---------

3.6.1 Circuit diagram, E0186-129 for P8528

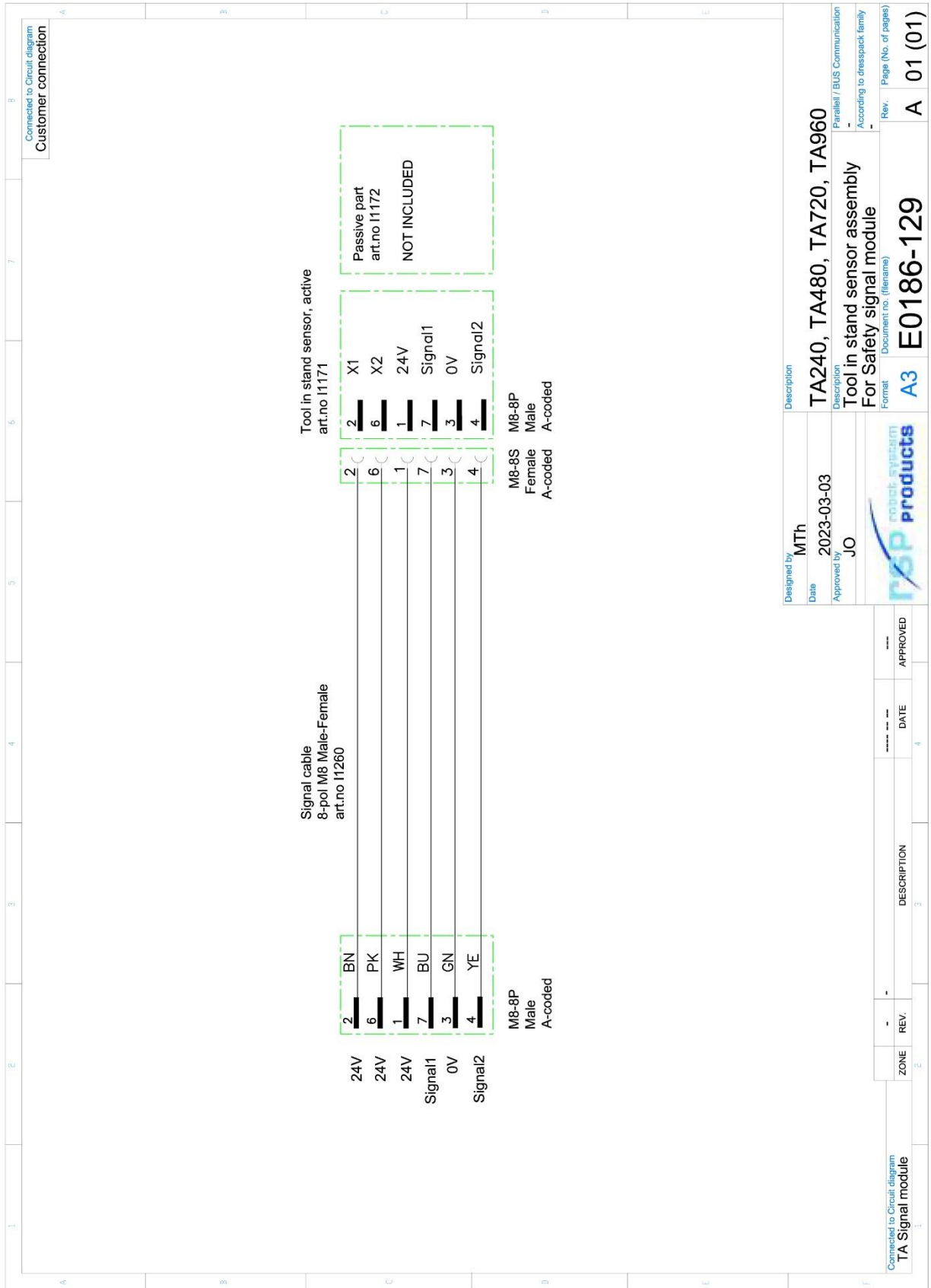

3.7 Analog pressure sensor. Article: P7257A



One pressure sensor which gives an analogue signal dependent on the pressure on the unlocking side of the locking piston and another pressure sensor which gives an analogue signal dependent on the pressure on the locking side of the locking piston.



NOTE!

To be used with tool changers Type B and Type C.

Technical data

Weight		0.2 kg
Electrical signals	Circuit diagram	E0203-377 (section 3.7.1)
	M8 3P	TC_Close_Pressure, 24 V
	M8 3P	TC_Open_Pressure, 24 V

3.7.1 Circuit diagram, E0203-377 for P7257A

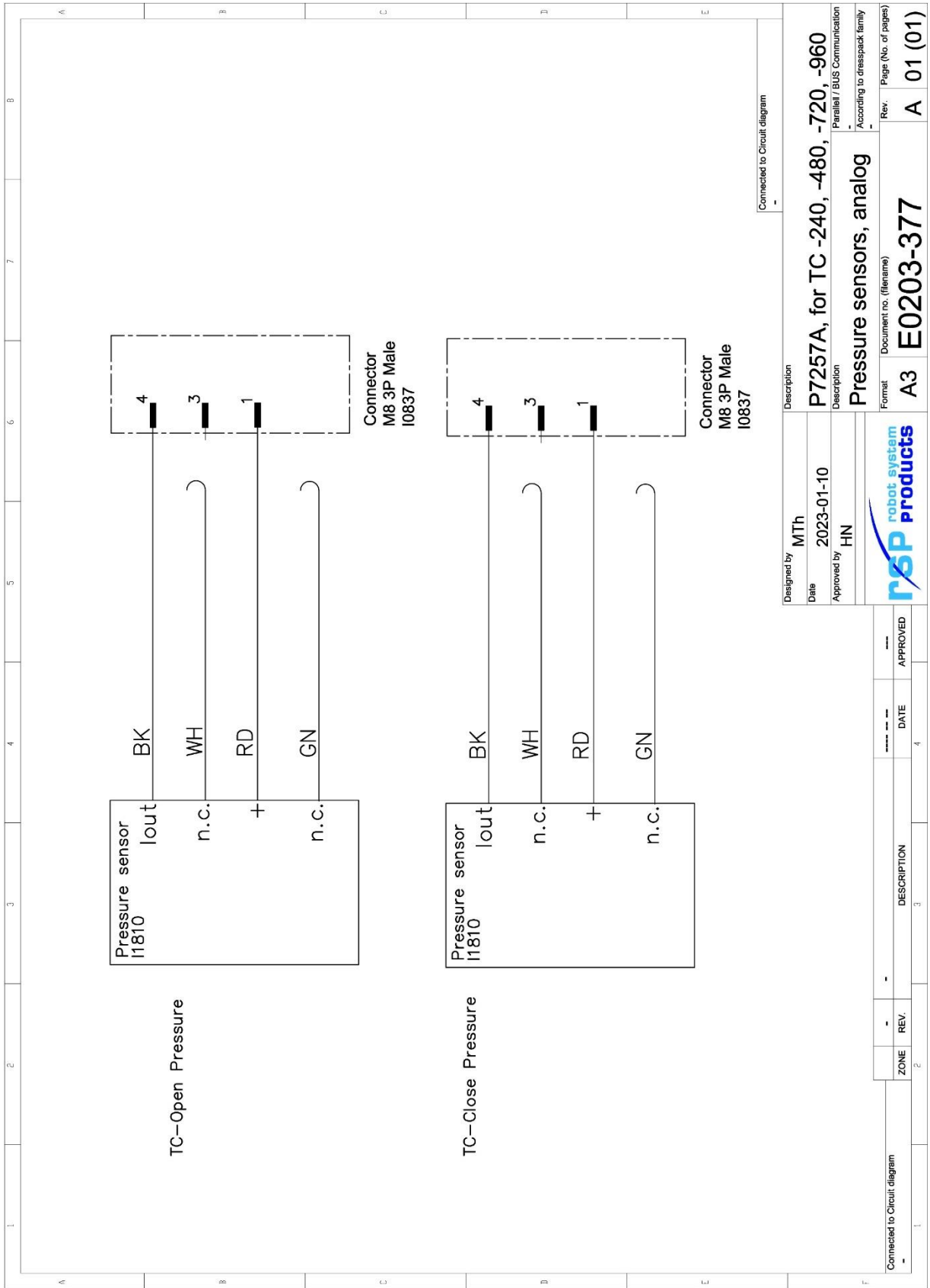

We reserve rights in this document and in the information contained therein. Reproduction, use or disclosure to third parties without express authority is strictly forbidden. Robot System Products

Designed by	MTh	Description	P7257A, for TC -240, -480, -720, -960
Date	2023-01-10	Description	Parallel / BUS Communication
Approved by	HN	Description	Pressure sensors, analog
Format		Document no. (filename)	Rev. Page (No. of pages)
A3		E0203-377	A 01 (01)

ZONE	REV.	DESCRIPTION	DATE	APPROVED
1				

3.8 TC Empty sensor. Article: P7145-1

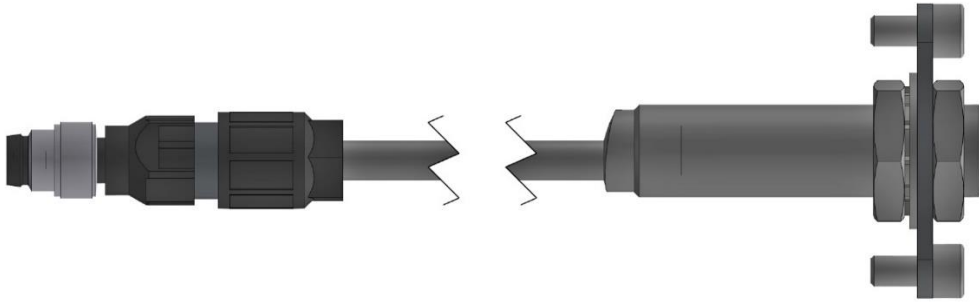

One inductive sensor which gives +24V signal "TC Empty" when tool attachment is not present at tool changer. To be mounted at position **E** on the tool changer.



NOTE!

To be used with tool changers Type B and Type C.

Technical data

Weight		0.05 kg
Electrical signals	Circuit diagram M8 8P	E0203-078 (section 3.8.1) TC_Empty, 0V, 24 V

3.8.1 Circuit diagram, E0203-078 for P7145-1

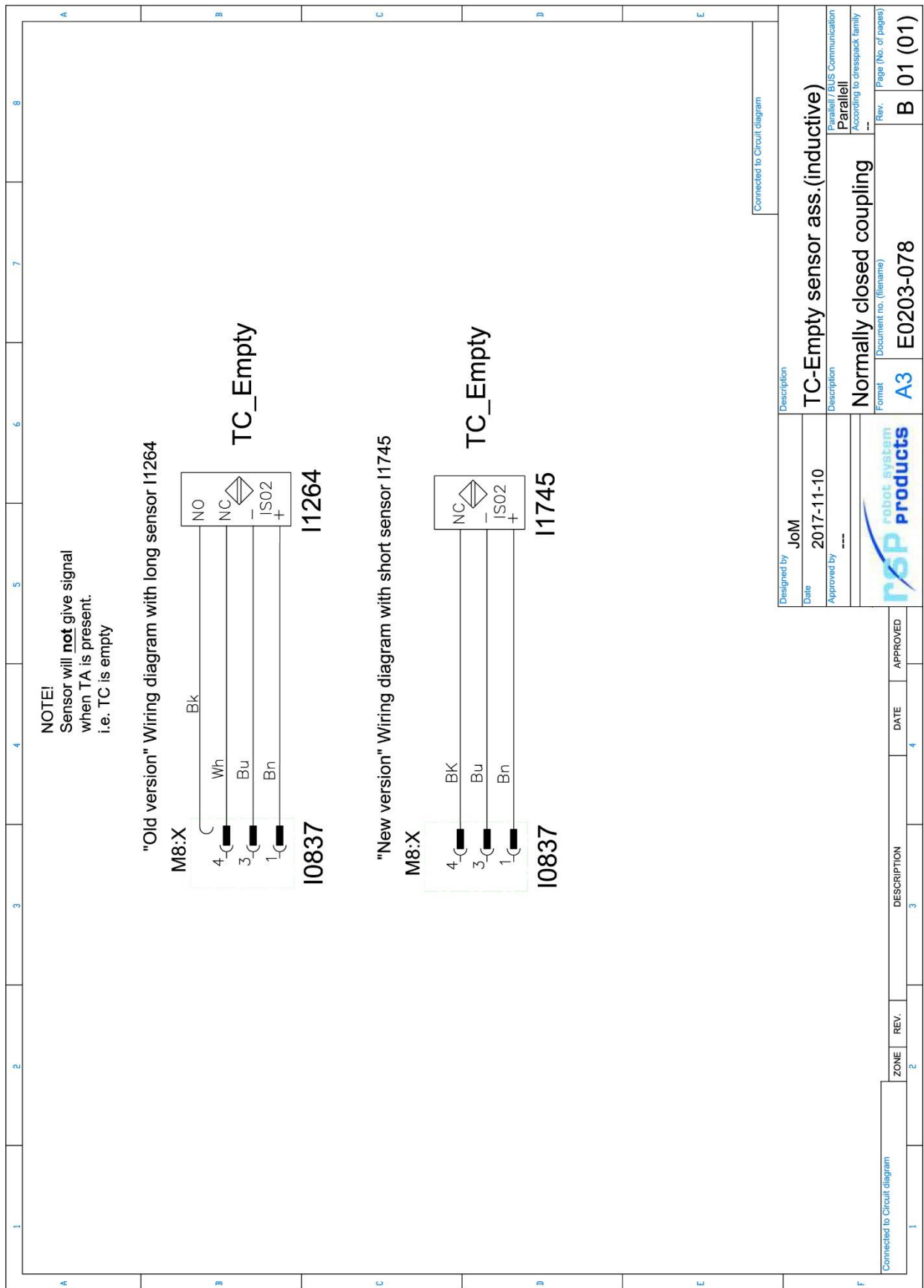

We reserve rights in this document and in the information contained therein. Reproduction use or disclosure to third parties without express authority is strictly forbidden. Robot System Products

3.9 TC Empty sensor, mechanical, robot side, Article: P7288

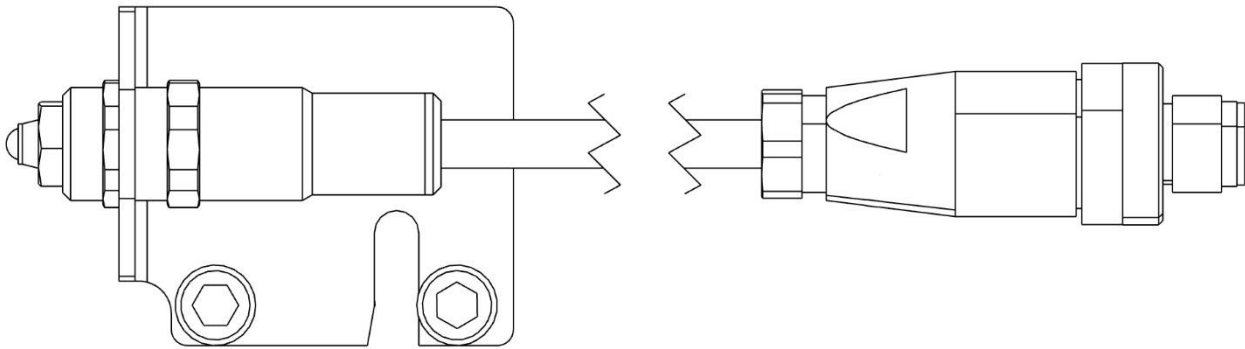

One mechanical sensor which gives +24V signal "TC Empty" when tool attachment is not present at tool changer. To be mounted at one dedicated position on tool changers type A and used together with TA Empty sensor receptor P7327.

Technical data

Weight		0.05 kg
Electrical signals	Circuit diagram	E0230-618 (section 3.10.1)
	Dedicated signals	TC Empty, 24V
	Connector	M12 5P, A-coded

3.10 TA Empty sensor receptor, tool side. Article: P7327

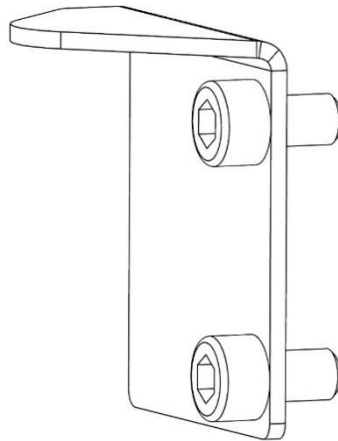

Empty sensor receptor to be used together with the TC Empty sensor P7288 and mounted at one dedicated position on tool attachment Type A.

Technical data

Weight	0.05 kg
---------------	---------

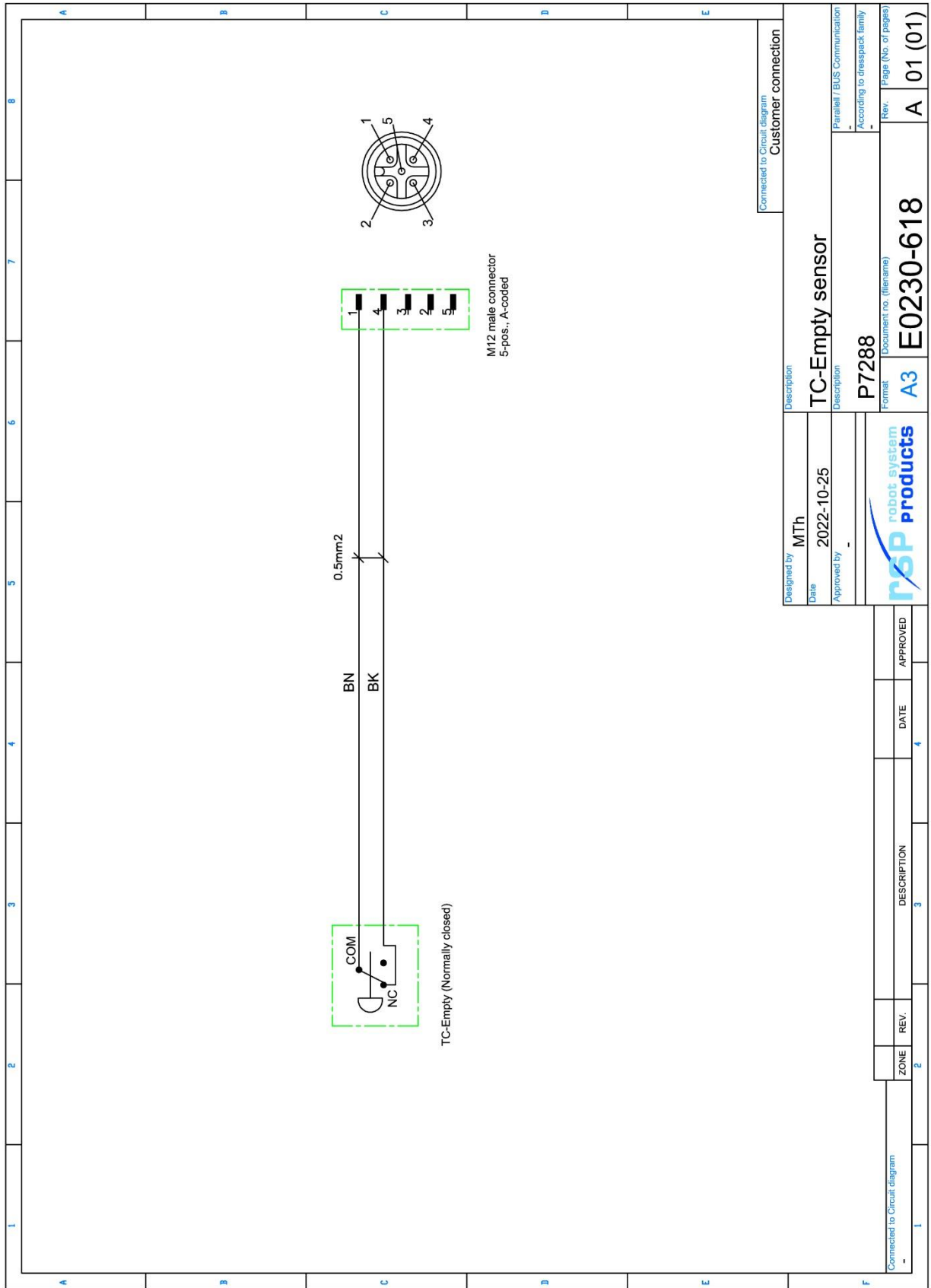

3.10.1 Circuit diagram, E0230-618 for P7288



We reserve rights in this document and in the information contained therein.
Reproduction, use or disclosure to third parties without express authority
is strictly forbidden. Robot System Products

4 ADAPTATION KITS FOR SIGNAL MODULES

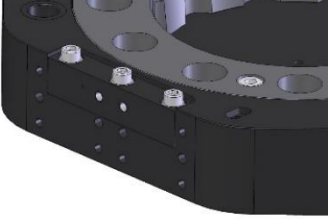
Adaption kits to be used on certain tool changers for mounting of signal modules.

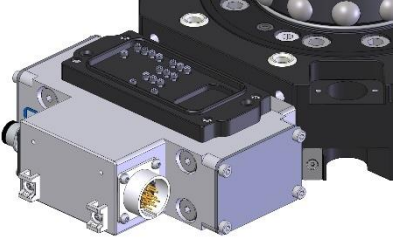
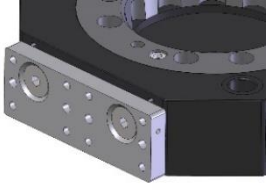
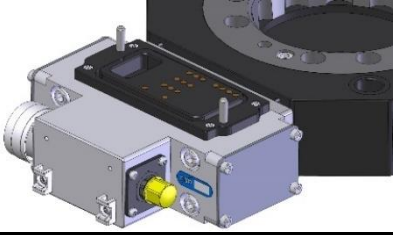
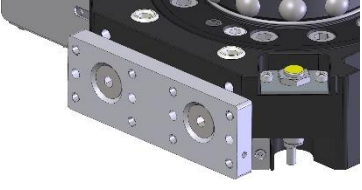
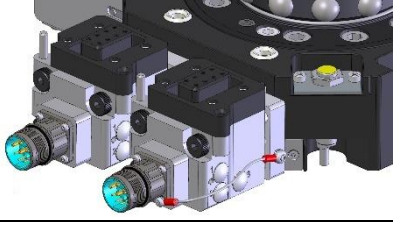
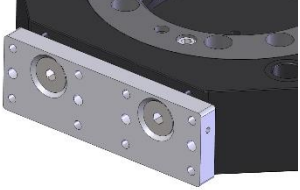
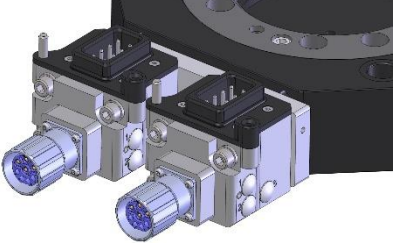
Adapt. kit	To be used at	Mounted adaptation kit	Mounted module
For one Large module, one Small power module or one or two Small signal modules			
P7246	Tool changer Type C and Tool attachment Type C		
For one Large module or one or two Small signal modules			
P7323	Tool changer Type A, B and C		
P7324	Tool attachment Type A, B and C		
For two Small power modules			
P7315	Tool changer Type A, B and C		
P7316	Tool attachment Type A, B and C		

4.1 Adaptation kit for Large and Small modules, Type C. Article: P7246

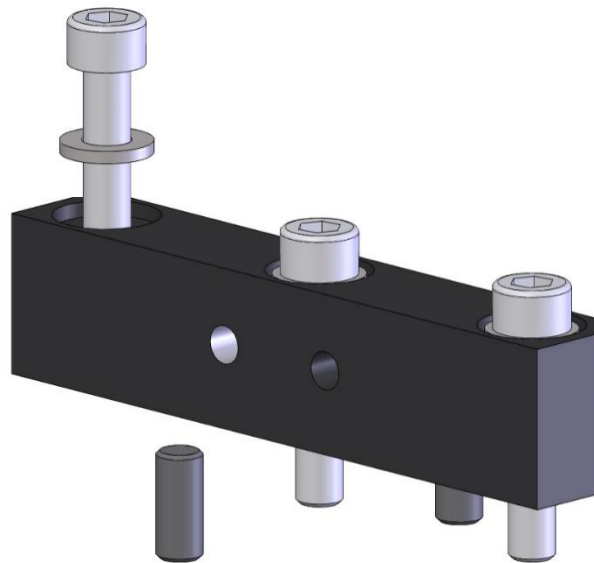

To be used on both tool changer and tool attachment, one on each side, for mounting of Large and Small signal modules on tool changers and tool attachments Type C. Shall be mounted at position **1+2** on the tool changer and the corresponding position on the tool attachment (section 2.3).



NOTE! Can be mounted only when Safety signal module P7501-XXX is not used on the tool changer and tool attachment.

Technical data

Weight	0.1 kg
---------------	--------

4.2 Adaptation kit for Large and Small signal modules, TC side. Article: P7323

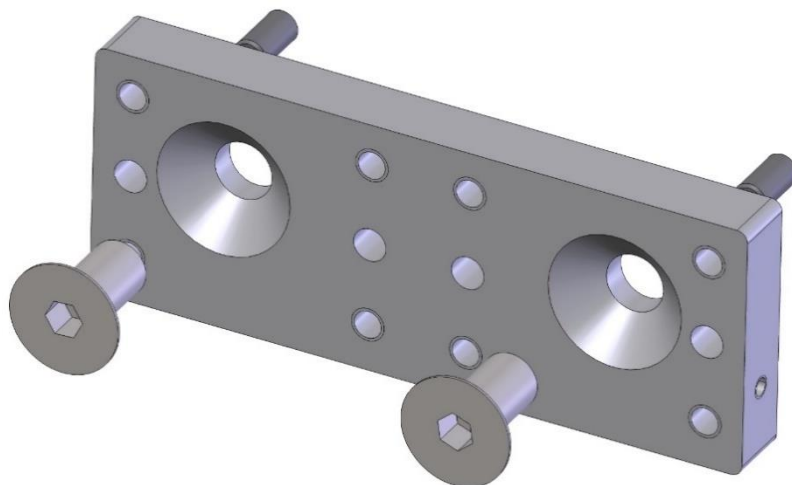

To be used for mounting of Small and Large signal modules on tool changers Type A, B and C according to the table above. Can be mounted at position **3** and **4** on the tool changer. To be used together with P7324.

Technical data

Weight	0.2 kg
Thickness	12 mm

4.3 Adaptation kit for Large and Small signal modules, TA side. Article: P7324

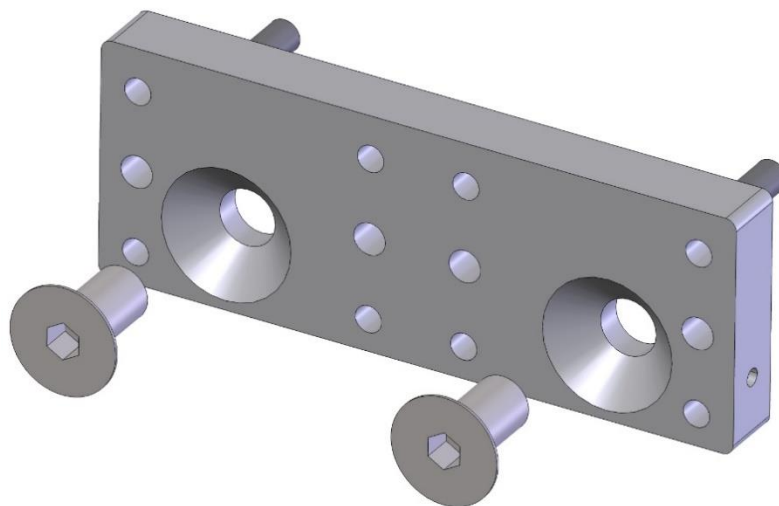

To be used for mounting of Small and Large signal modules on tool attachments Type A, B and C according to the table above. To be mounted at the tool attachment on the corresponding position as P7323.

Technical data

Weight	0.2 kg
Thickness	12 mm

4.4 Adaptation kit for two Small power modules, TC side. Article: P7315

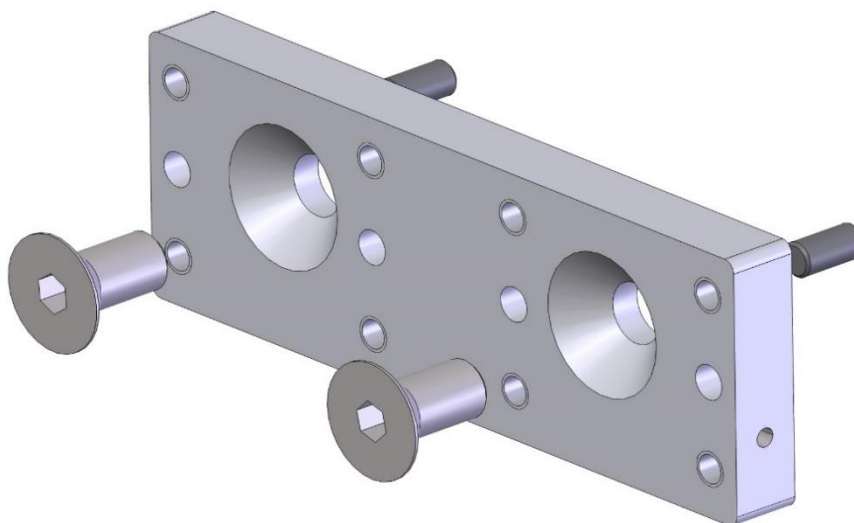

To be used for mounting of two Small power modules on tool changers Type A, B and C according to the table above. Can be mounted at position **3** and **4** on the tool changer. To be used together with P7316.

Technical data

Weight	0.2 kg
Thickness	12 mm

4.5 Adaptation kit for two Small power modules, TA side. Article: P7316

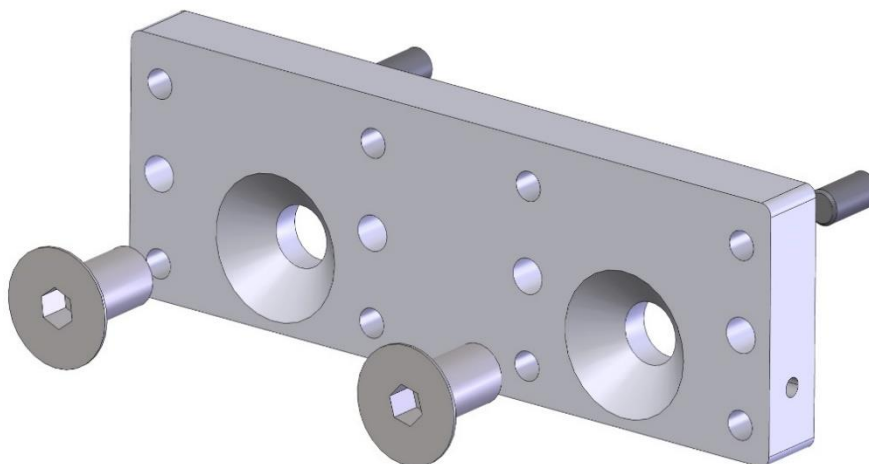

To be used for mounting of two Small power modules on tool attachments Type A, B and C according to the table above. To be mounted at the tool attachment on the corresponding position as P7315.

Technical data

Weight	0.2 kg
Thickness	12 mm

5 SMALL SIGNAL MODULES

5.1 Signal module 17x, robot side. Article: P6738-1

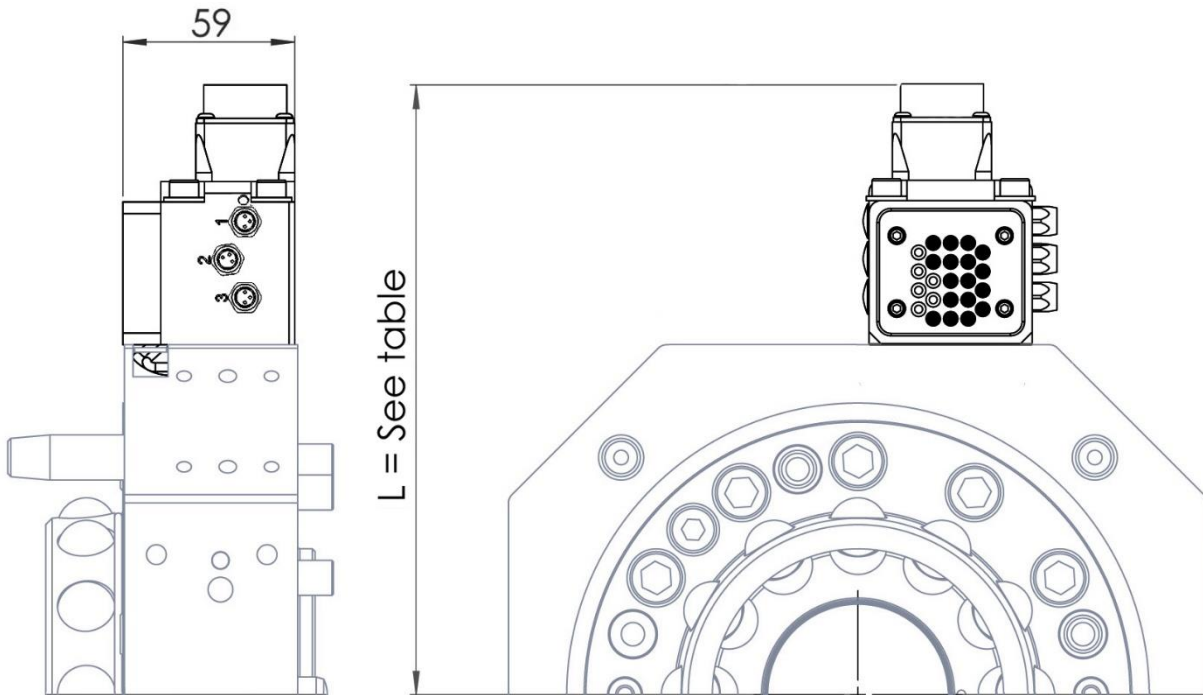

Distance from center of tool changer (L)		
Tool changer	Without adapter plate	With adapter plate (P7323)
TC240	189 mm	201 mm
TC480	209 mm	221 mm
TC720	229 mm	241 mm
TC960	264 mm	276 mm

Signal module P6738-1 transfers 16 electrical signals to the tool attachment. To be used together with option P6739 attached to the tool attachment.

On the housing 3 separate M8-contacts for connecting integrated valve and magnetic sensors are mounted, which can be used for sensor-options P6789, P7173, P7174, P7293 or P7175 and Integrated valves P6718 or P7710.

Technical data

Weight		0.2 kg
Electrical signals	Circuit diagram Souriau 23P (UT001823PH) Dedicated signals, 3 x M8 3S	E0178-246 (section 5.1.1) 16 x (2A, 60V) + PE 24V (for sensors) 0V (for valves and sensors) TC Opened (sensor) TC Closed (sensor) doOpen TC 1 (valve) doOpen TC 2 (valve)
Connection kits (optional)	P8002 (connector) P8002-1 (connector)	Souriau 23S (straight) Souriau 23S (angled)

5.1.1 Circuit diagram E0178-246 for P6738-1

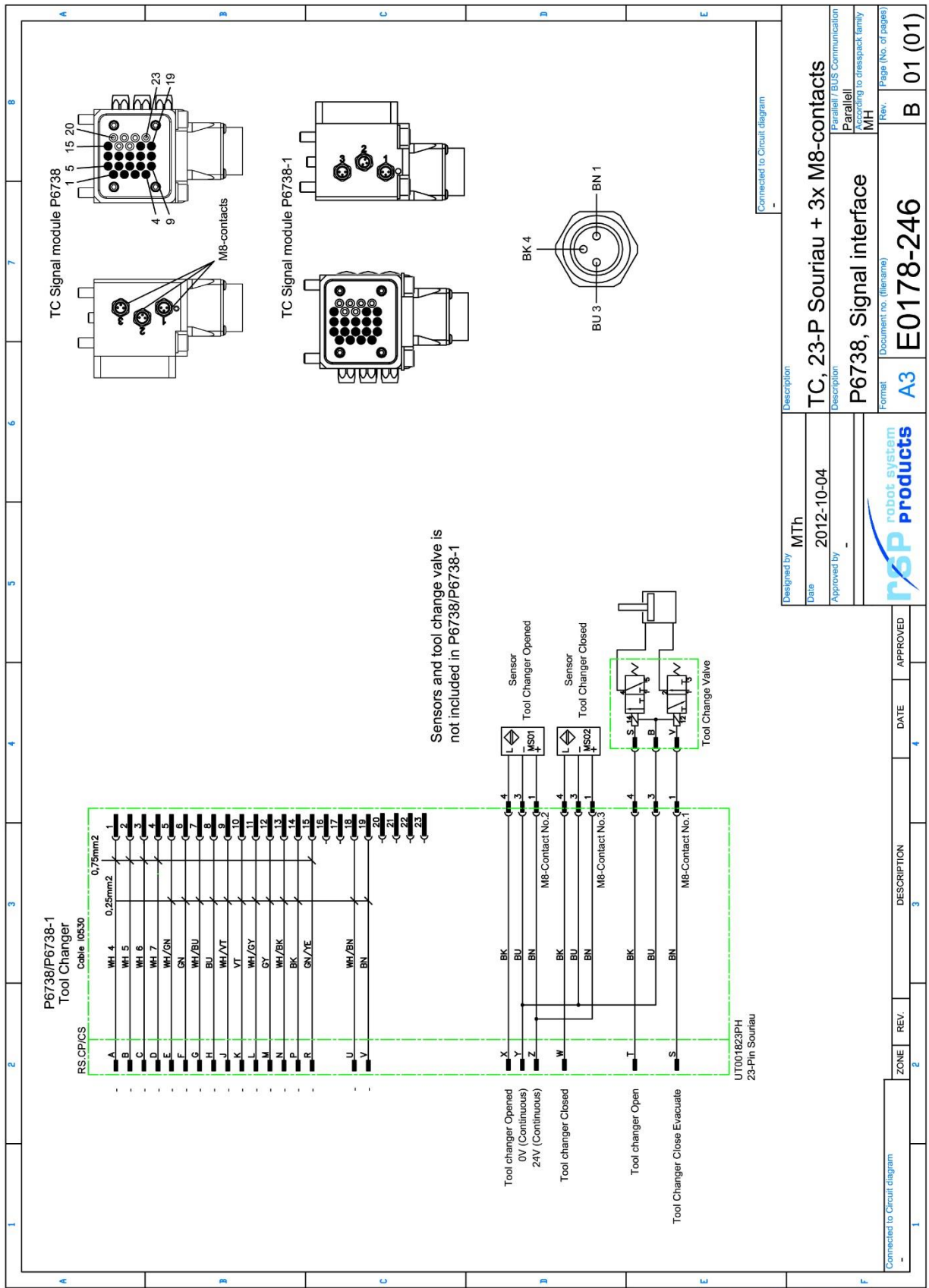

Designed by	MTh	Description	TC, 23-P Souriau + 3x M8-contacts
Date	2012-10-04	Description	Parallel / BUS Communication
Approved by		Description	P6738, Signal interface
Format	Document no. (filename)	Format	According to dresspack family
Rev.		Rev.	MH
		Page (No. of pages)	B 01 (01)

robot system
RSP products

We reserve rights in this document and in the hardware contained therein. Reproduction, use or disclosure to third parties without express authority is strictly forbidden. Robot System Products

5.2 Signal module 17x, tool side, Article: P6739

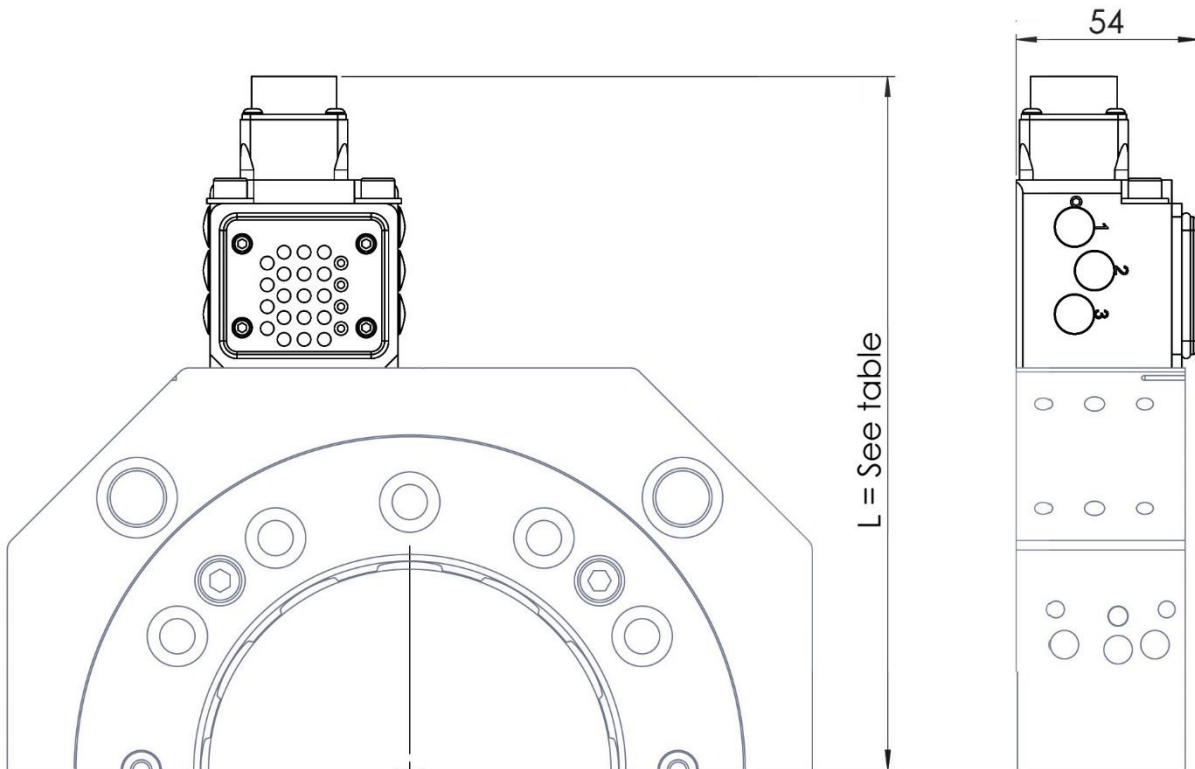

Distance from center of tool attachment (L)		
Tool attachment	Without adapter plate	With adapter plate (P7324)
TA240	187 mm	199 mm
TA480	207 mm	219 mm
TA720	227 mm	239 mm
TA960	262 mm	274 mm

Signal module P6739 transfers 16 electrical signals to the tool. To be mounted at the tool attachment and used together with option P6738-1 attached to the tool changer.

Technical data

Weight		0.2 kg
Electrical signals	Circuit diagram Souriau 19S (UT001619SH)	E0178-247 (section 5.2.1) 16 signals + PE
Connection kits (optional)	P8003 (connector) P8003-1 (connector)	Souriau 19P (straight) Souriau 19P (angled)

5.3 Signal module 19x, robot side. Article: P7224

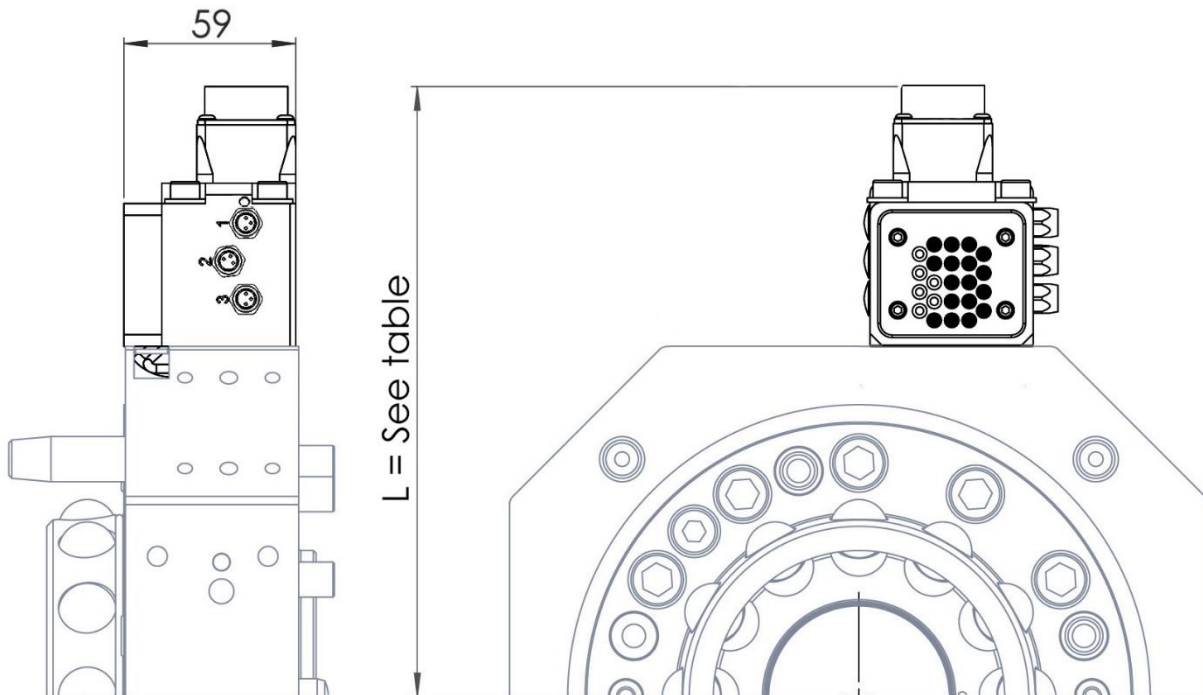

Distance from center of tool changer (L)		
Tool changer	Without adapter plate	With adapter plate (P7323)
TC240	187 mm	199 mm
TC480	207 mm	219 mm
TC720	227 mm	239 mm
TC960	262 mm	274 mm

Signal module P7224 transfers 19 electrical signals to the tool attachment. To be used together with option P7225 attached to the tool attachment.

On the housing 3 separate M8-contacts for connecting integrated valve and magnetic sensors are mounted, which can be used for magnetic sensors P6789, P7173, P7174, P7293 or P7175 and Integrated valves P6718 or P7710.

Technical data

Weight		0.2 kg
Electrical signals	Circuit diagram Souriau 26P (UT001626PH) Dedicated signals, 3 x M8 3S	E0178-764 (section 5.3.1) 19 x (2A, 60V) + PE 24V (for tool attachment) 24V (for sensors) 0V (for valves and sensors) TC Opened (sensor) TC Closed (sensor) doOpen TC 1 (valve) doOpen TC 2 (valve)
Connection kits (optional)	P8025 (connector)	Compact Souriau 26S (straight)

5.3.1 Circuit diagram E0178-764 for P7224

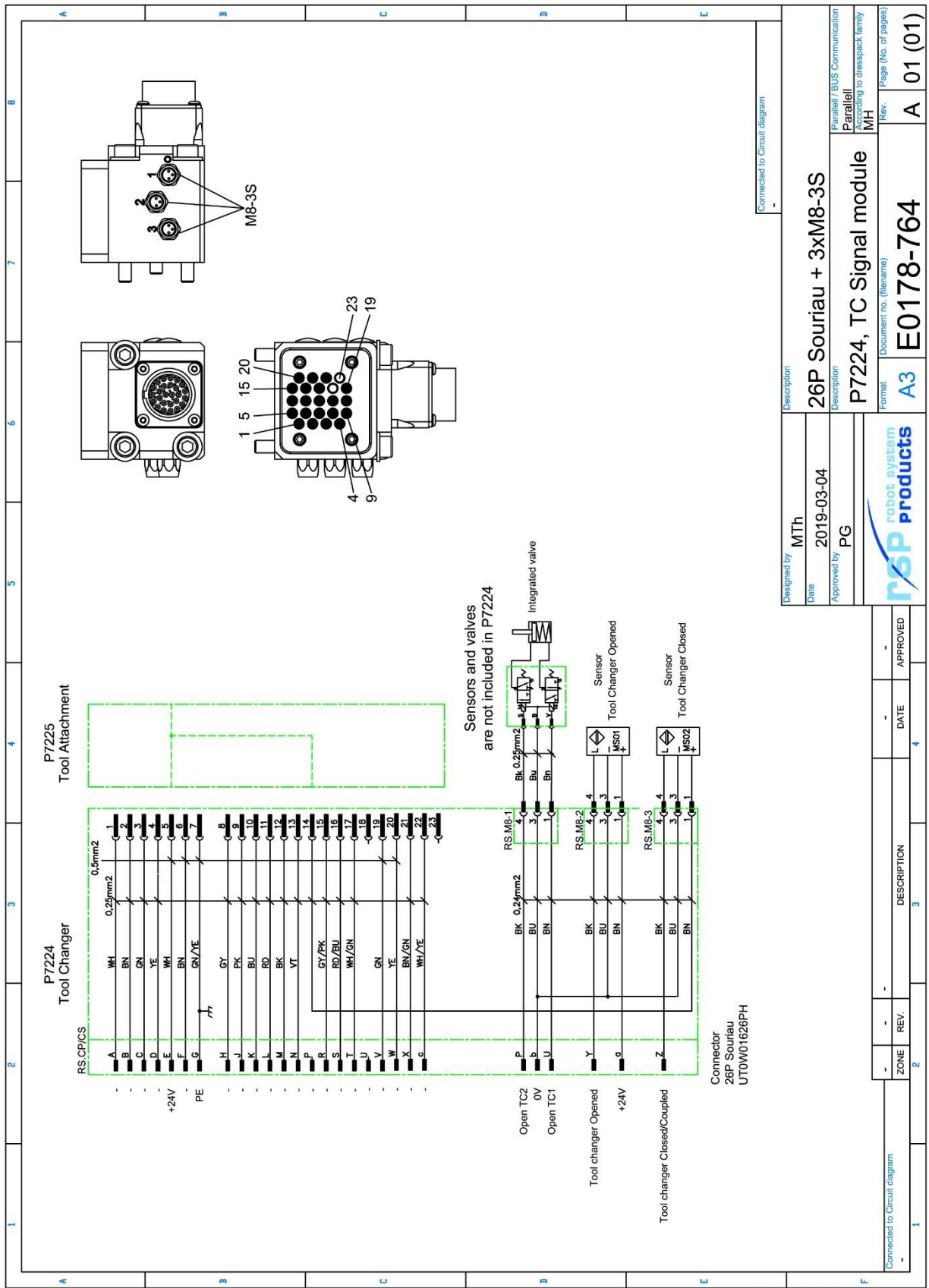

We reserve rights in this document and in the information contained therein. Reproduction or disclosure to third parties without express authority is strictly forbidden. Robot System Products

5.4 Signal module 19x, tool side, Article: P7225

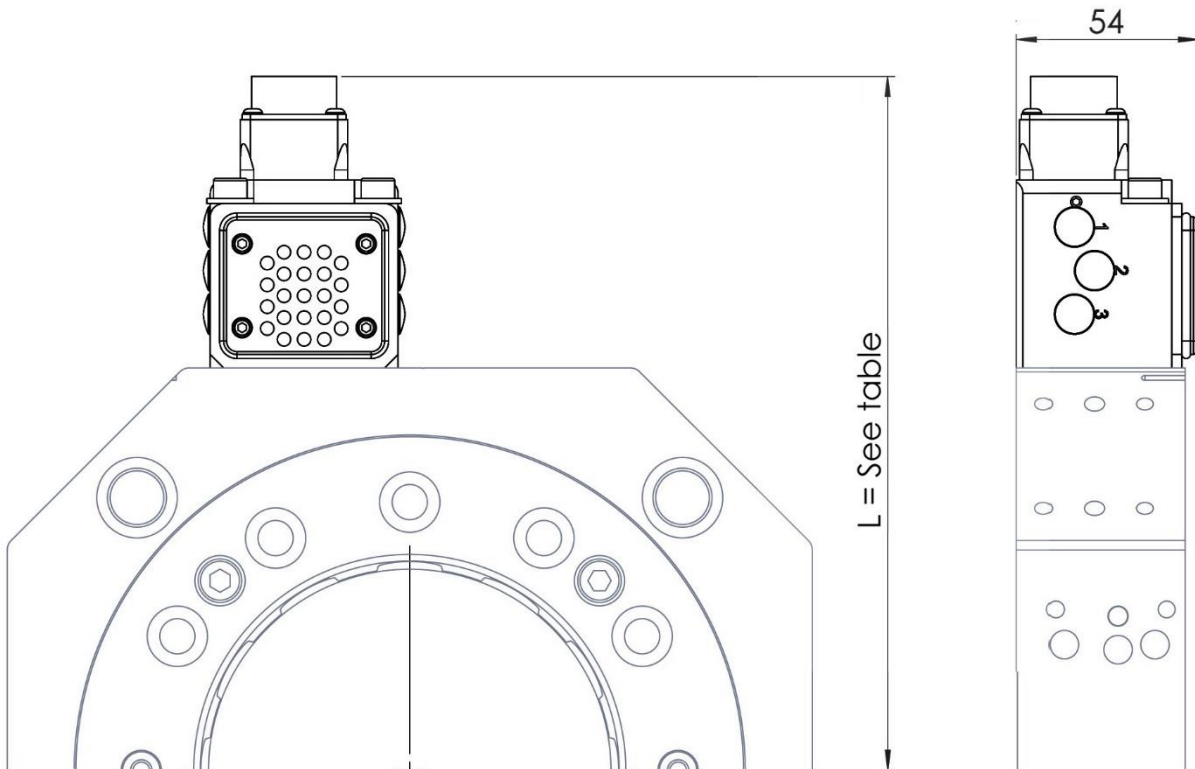

Distance from center of tool attachment (L)		
Tool attachment	Without adapter plate	With adapter plate (P7324)
TA240	187 mm	199 mm
TA480	207 mm	219 mm
TA720	227 mm	239 mm
TA960	262 mm	274 mm

Signal module P7225 transfers 19 electrical signals to the tool. To be mounted at the tool attachment and used together with option P7224 attached to the tool changer.

Technical data

Weight		0.2 kg
Electrical signals	Circuit diagram Souriau 26S (UT001626SH)	E0178-765 (section 5.4.1) 19 signals + PE
Connection kits (optional)	P8012 (connector) P8012-1 (connector)	Souriau 26P (straight) Souriau 26P (angled)

5.4.1 Circuit diagram E0178-765 for P7225

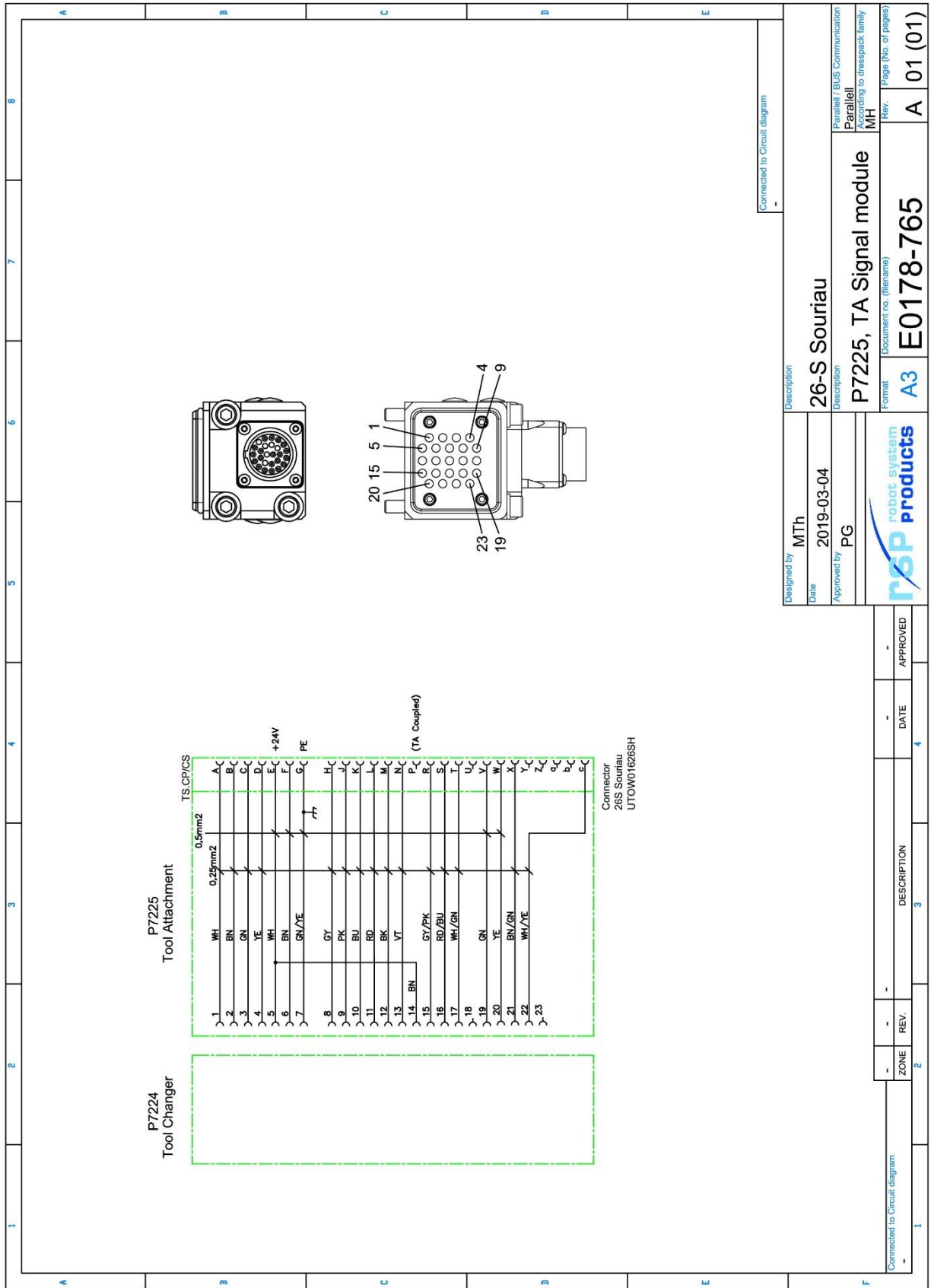

We reserve rights in this document and in the hardware covered thereby. Reproduction or disclosure to third parties without express authority is strictly forbidden. Robot System Products

5.5 Signal module 23x, robot side. Article: P6711

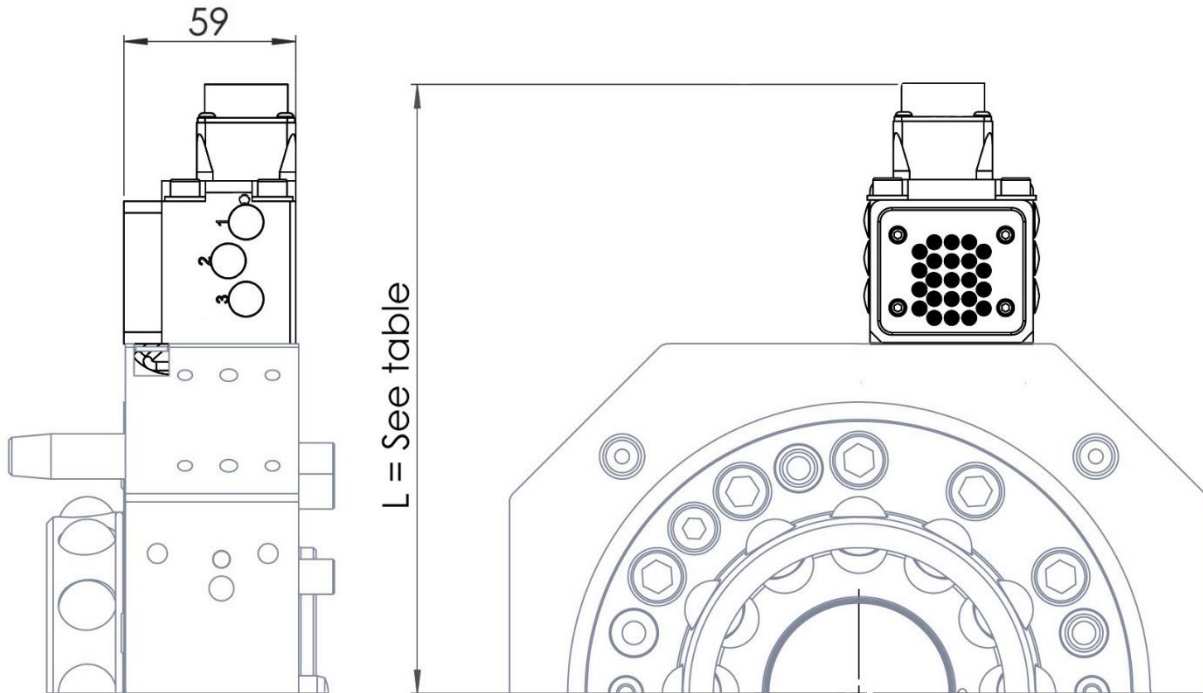

Distance from center of tool changer (L)		
Tool changer	Without adapter plate	With adapter plate (P7323)
TC240	189 mm	201 mm
TC480	209 mm	221 mm
TC720	229 mm	241 mm
TC960	264 mm	276 mm

Signal module P6711 transfers 23 electrical signals to the tool attachment. To be used together with option P6721 attached to the tool attachment.

Technical data

Weight		0.2 kg
Electrical signals	Circuit diagram Souriau 23P (UT001823PH)	E0178-207 (section 5.5.1) 23 x (2A, 60V)
Connection kits (optional)	P8002 (connector) P8002-1 (connector)	Souriau 23S (straight) Souriau 23S (angled)

5.6 Signal module 23x, tool side, Article: P6721

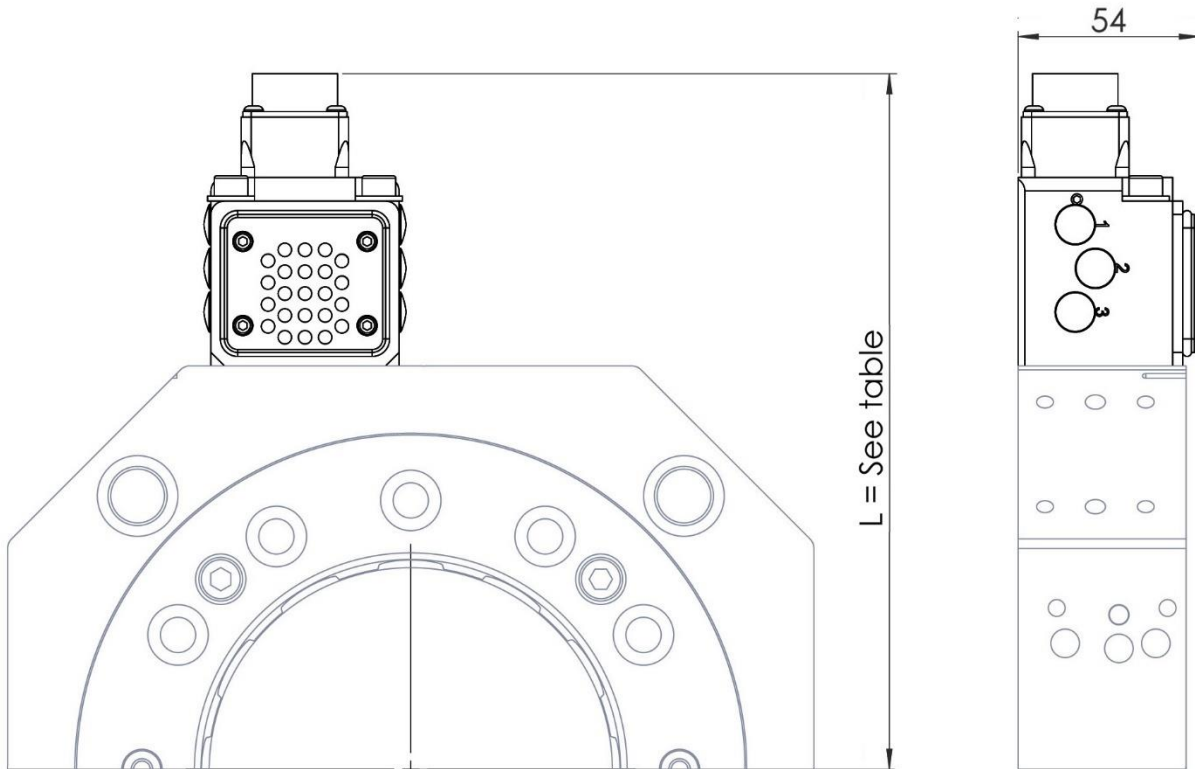

Distance from center of tool attachment (L)		
Tool attachment	Without adapter plate	With adapter plate (P7324)
TA240	189 mm	201 mm
TA480	209 mm	221 mm
TA720	229 mm	241 mm
TA960	264 mm	276 mm

Signal module P6721 transfers 23 electrical signals to the tool. To be mounted at the tool attachment and used together with option P6711 attached to the tool changer.

Technical data

Weight		0.2 kg
Electrical signals	Circuit diagram Souriau 23S (UT001823SH)	E0178-208 (section 5.6.1) 23 signals
Connection kits (optional)	P8001 (connector) P8001-1 (connector)	Souriau 23P (straight) Souriau 23P (angled)

5.6.1 Circuit diagram E0178-208 for P6721

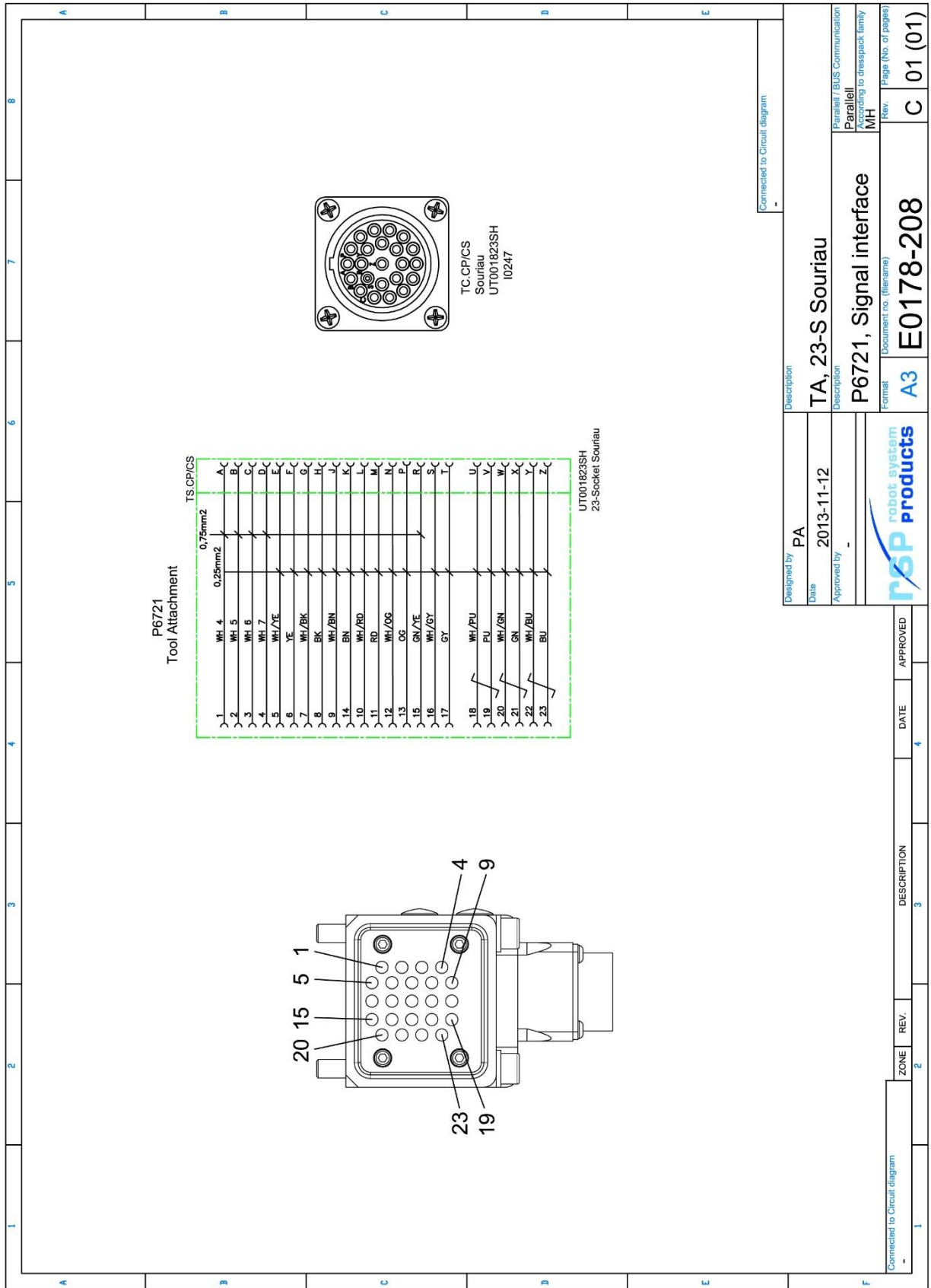

We reserve rights in this document and in the hardware covered thereby. Reproduction or disclosure to third parties without express authority is strictly forbidden. Robot System Products

5.7 Bus module, Profinet, robot side. Article: P6771

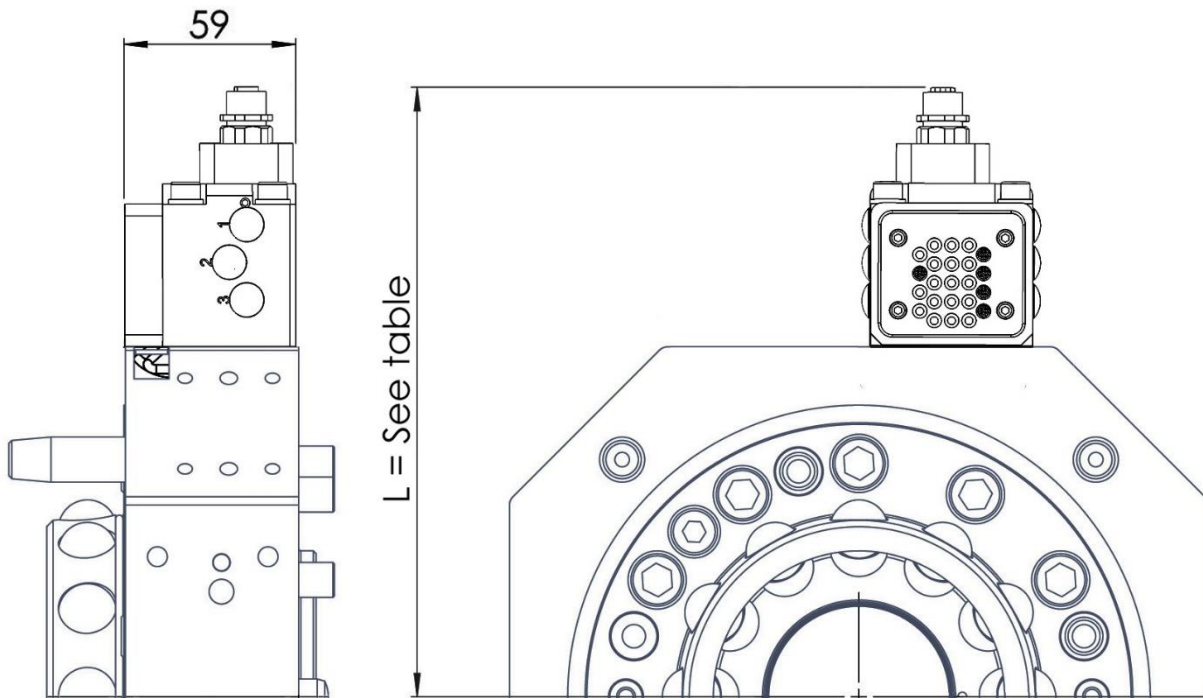

Distance from center of tool changer (L)		
Tool changer	Without adapter plate	With adapter plate (P7323)
TC240	199 mm	211 mm
TC480	219 mm	231 mm
TC720	239 mm	252 mm
TC960	274 mm	286 mm

Bus module P6771 transfers 4 field bus signals to the tool attachment. To be used together with option P6775 attached to the tool attachment.

Technical data

Weight		0.2 kg
Field bus	Field bus type Circuit diagram M12 4S D-coded	Profinet, Ethernet, EtherCAT E0178-317 (section 5.7.1) 4 field bus channels
Connection kits (optional)	I1175 (field bus)	M12 4P D-coded

5.7.1 Circuit diagram E0178-317 for P6771

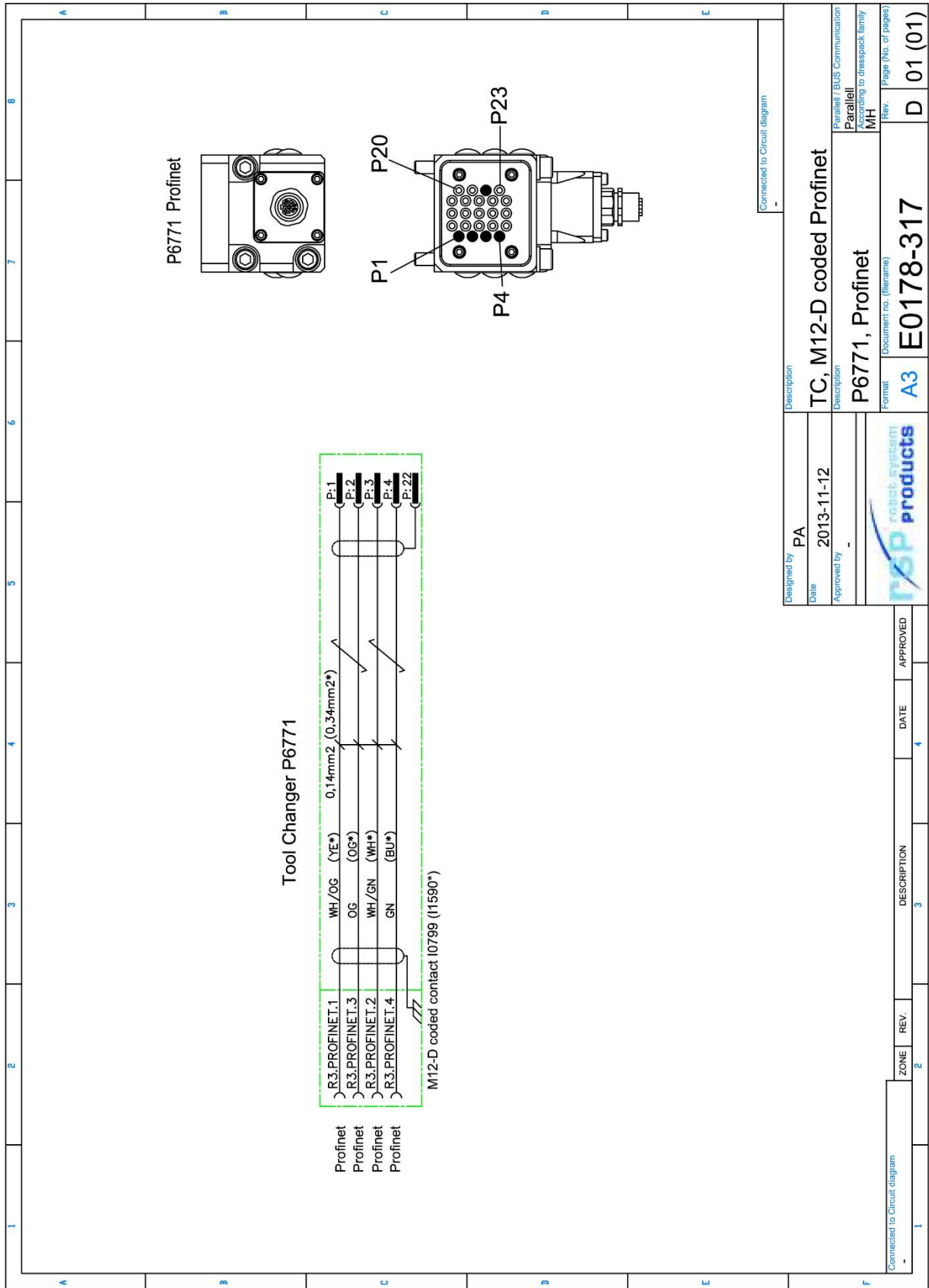

We reserve rights in this document and in the hardware contained therein.
Reproduction or disclosure to third parties without express authority
is strictly forbidden. Robot-System-Products

5.8 Bus module, Profinet, tool side, Article: P6775

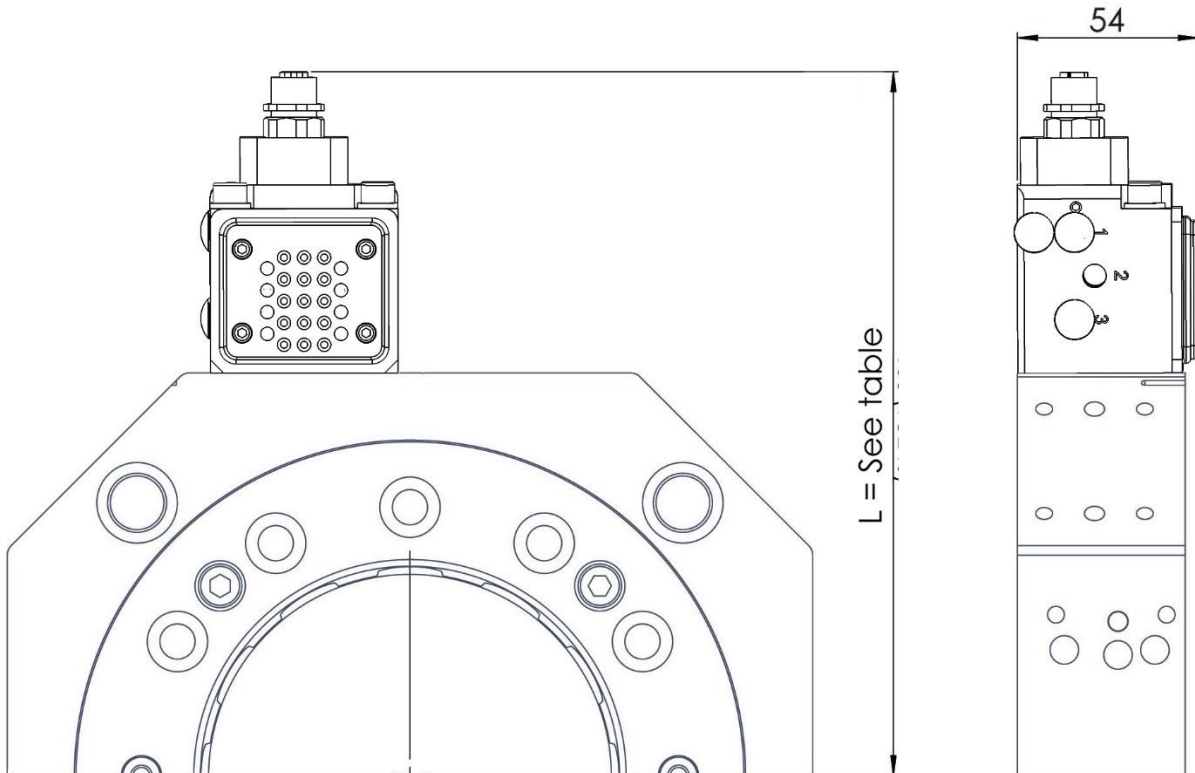

Distance from center of tool attachment (L)

Tool attachment	Without adapter plate	With adapter plate (P7324)
TA240	199 mm	211 mm
TA480	219 mm	231 mm
TA720	239 mm	252 mm
TA960	274 mm	286 mm

Bus module P6775 transfers 4 field bus signals to the tool. To be mounted at the tool attachment and used together with option P6771 attached to the tool changer.

Technical data

Weight		0.2 kg
Field bus	Circuit diagram M12 4P D-coded	E0178-320 (section 5.8.1) 4 field bus channels
Connection kits (optional)	I1257 (field bus)	M12 4S D-coded

5.8.1 Circuit diagram E0178-320 for P6775

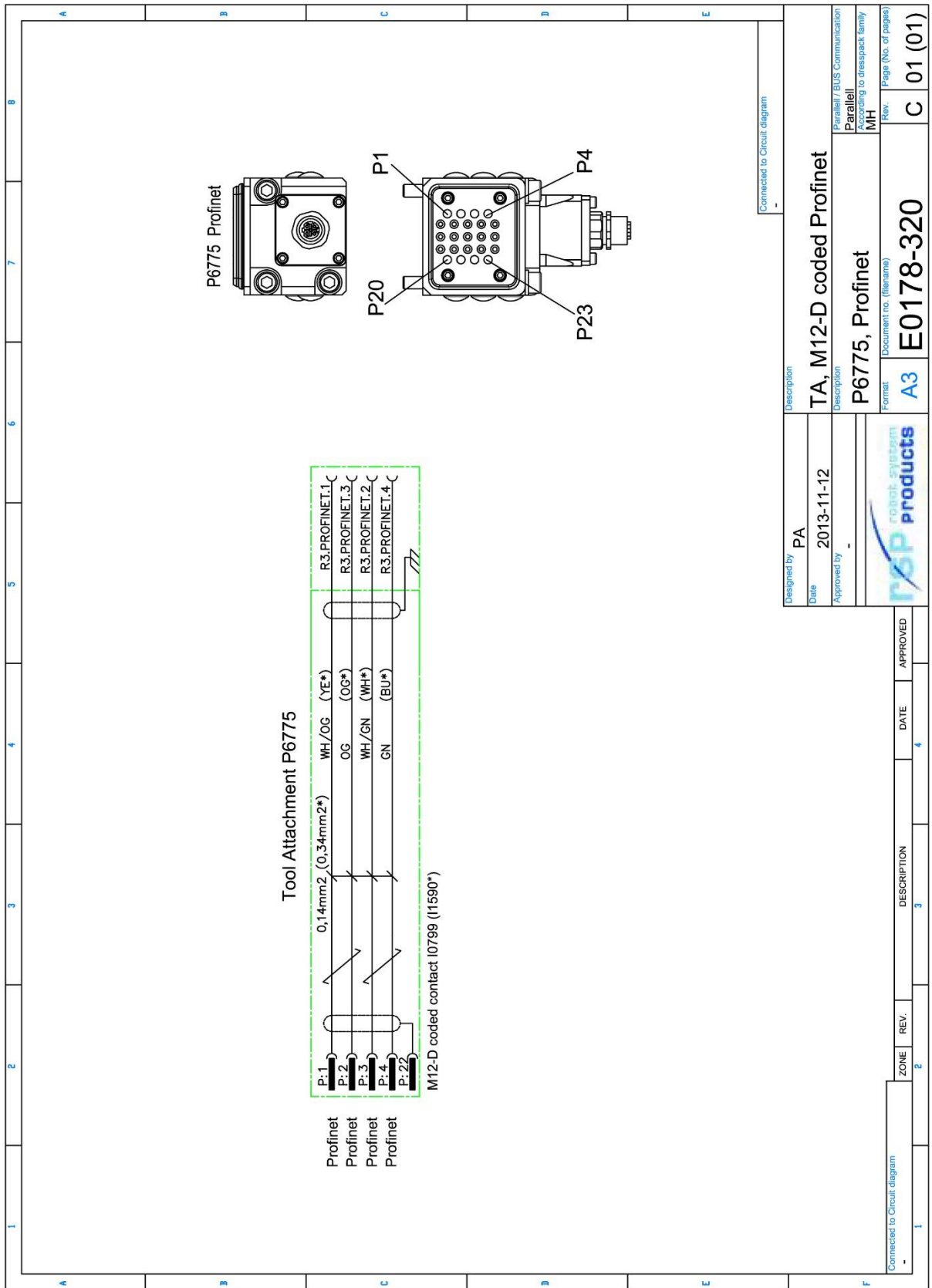

We reserve rights in this document and in the information contained therein. Reproduction, use or disclosure to third parties without express authority is strictly forbidden. Robot System Products

5.9 Contact cover for Small signal modules, tool side. Article: P7262

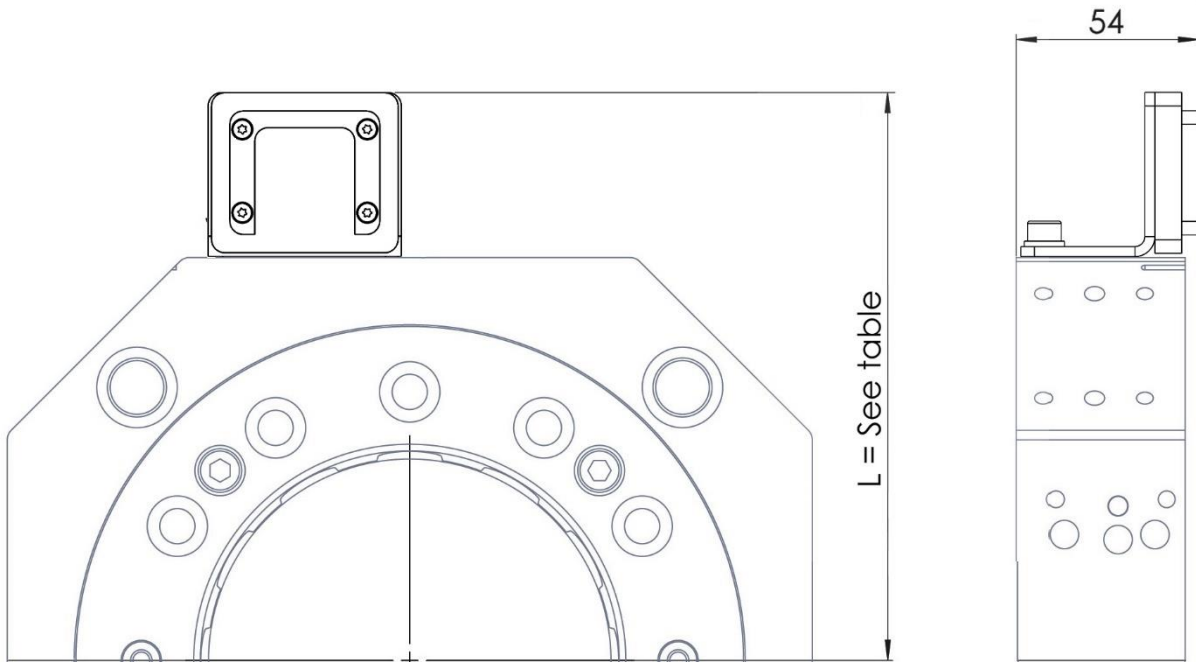

Distance from center of tool attachment (L)		
Tool attachment	Without adapter plate	With adapter plate (P7324)
TA240	149 mm	161 mm
TA480	169 mm	181 mm
TA720	189 mm	201 mm
TA960	224 mm	236 mm

To be mounted on the TA and used together with options P6738-1, P7224, P6711 and P6771 on the TC-side when no corresponding Small signal module is used on tool attachment.

Technical data

Weight	0.2 kg
--------	--------

6 SMALL POWER MODULES

6.1 Power module M23, robot side. Article: P6768-2

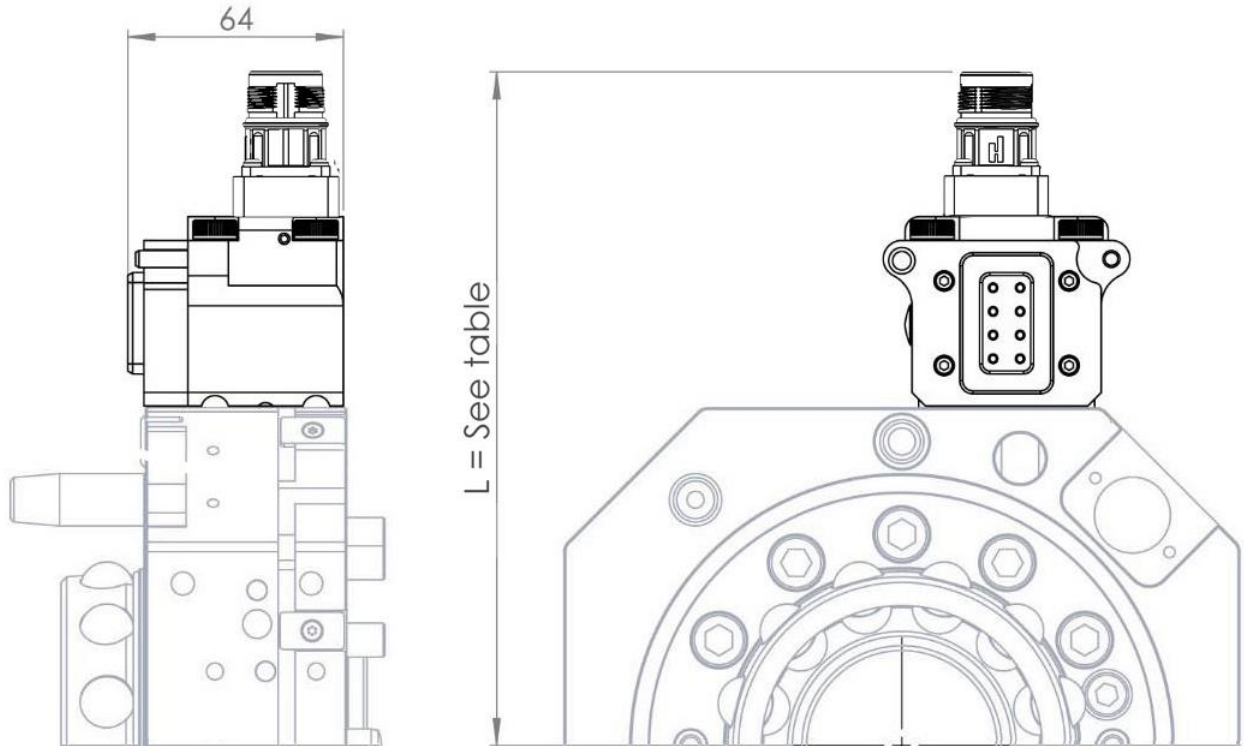

Distance from center of tool changer (L)		
Tool changer	Without adapter plate	With adapter plate (P7315)
TC240	199 mm	211 mm
TC480	219 mm	231 mm
TC720	239 mm	252 mm
TC960	274 mm	286 mm

Power module M23 P6768-2 transfers 8 servo power signals to the tool attachment. To be mounted on the tool changer and used together with option P6772-2 attached to the tool attachment.

Technical data

Weight		0.2 kg
Servo power	Circuit diagram M23 8P (Hummel 7.601.000.000, insert 7.084.943.121)	E0178-314 (section 6.1.1) 4 x (5A, 300V) + 3 x (15A, 600V) + PE
Connection kits (optional)	P8030 (Connector) P8030-1 (Connector)	M23 8S (straight) M23 8S (angled)

6.1.1 Circuit diagram E0178-314 for P6768-2

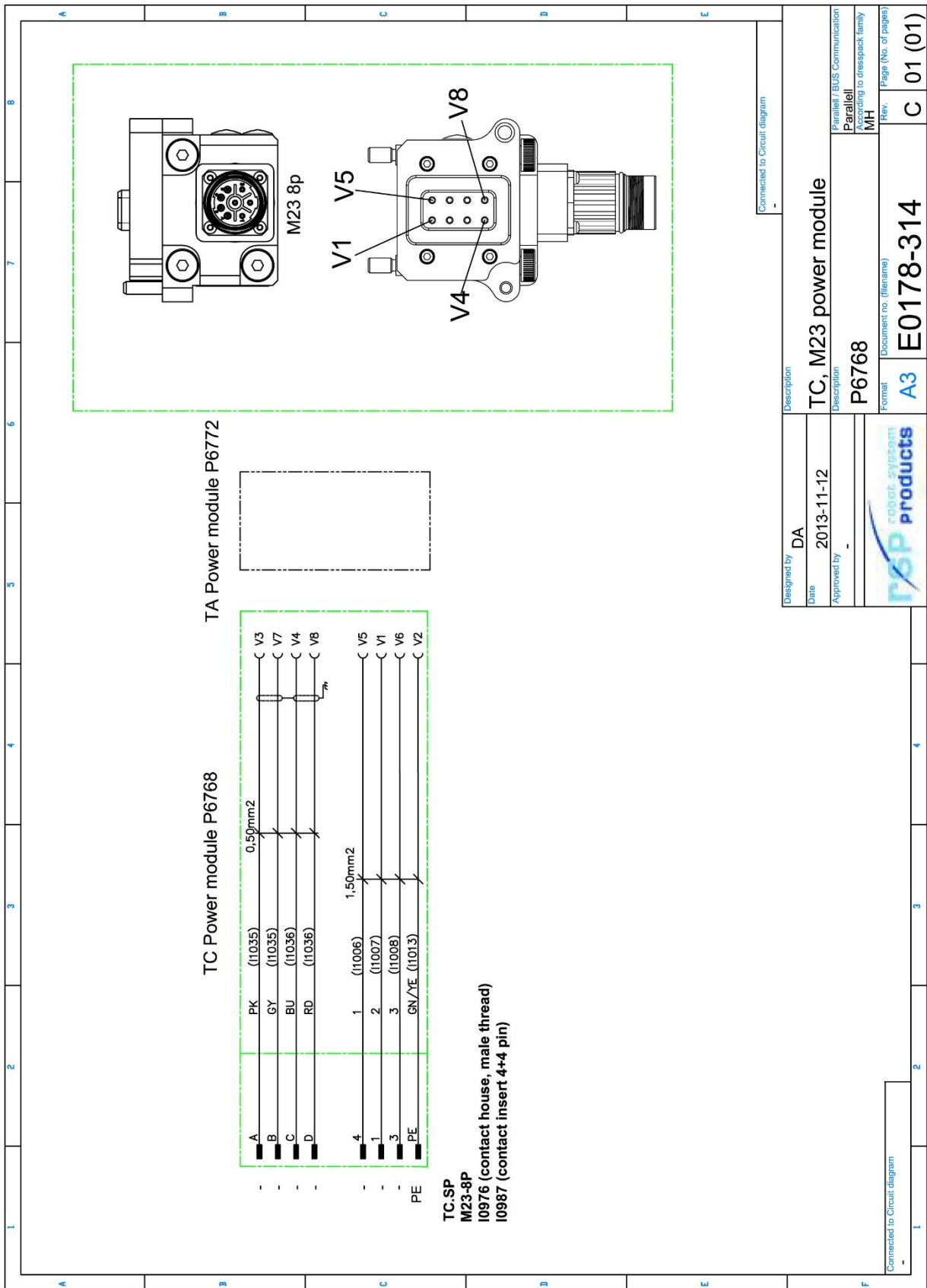

We reserve rights in this document and in the information contained therein.
 It is strictly forbidden to reproduce or disclose to third parties without express authority.
 © 2013, Rockwell Automation, Rockwell System Products

Designed by	DA	Description	TC, M23 power module
Date	2013-11-12	Description	P6768
Approved by	-	Format	A3
		Document no. (filename)	E0178-314
		Revision	C 01 (01)

Parallel / BUS Communication
 Parallel
 MH
 MH
 Page (No. of pages)

6.2 Power module M23, tool side, Article: P6772-2

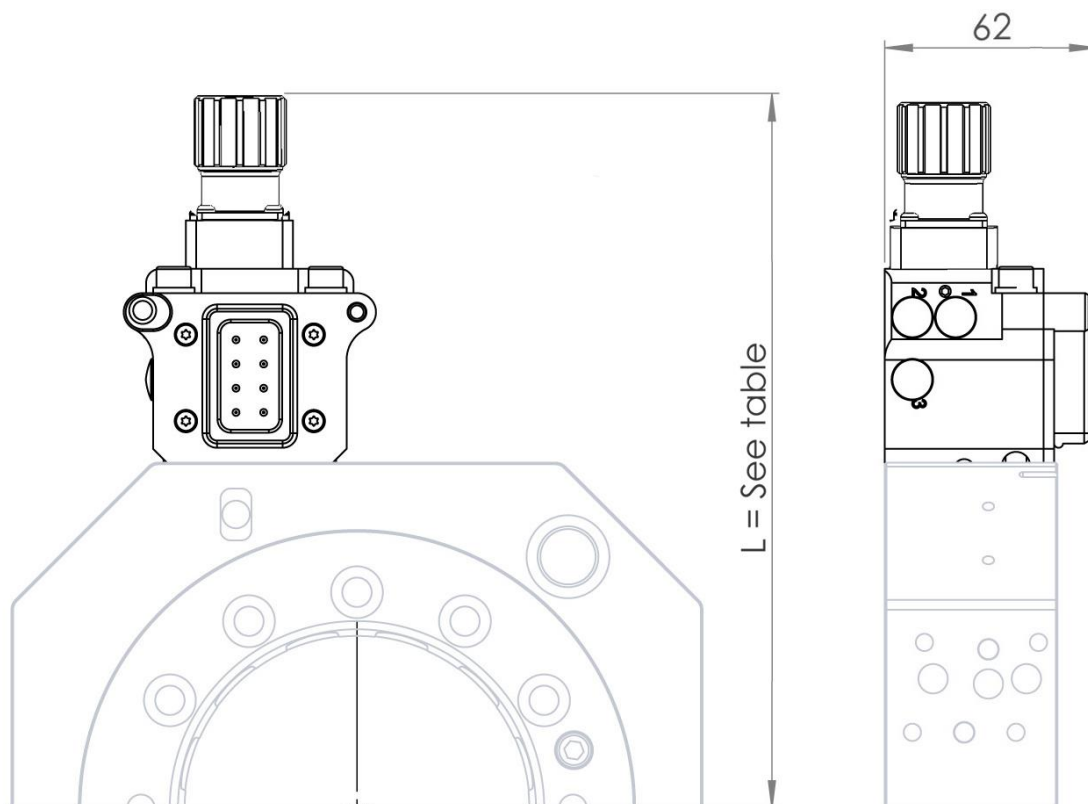

Distance from center of tool attachment (L)		
Tool attachment	Without adapter plate	With adapter plate (P7316)
TA240	204 mm	216 mm
TA480	224 mm	236 mm
TA720	244 mm	256 mm
TA960	279 mm	291 mm

Power module M23 P6772-2 transfers 8 servo power signals to the tool. To be mounted at the tool attachment and used together with option P6768-2 attached to the tool changer.

Technical data

Weight		0.2 kg
Servo power	Circuit diagram M23 8S (Hummel 7.641.000.000, insert 7.084.943.102)	E0178-321 (section 6.2.1) 8 power signals
Connection kits (optional)	P8032 (Connector)	M23 8P (straight)

6.2.1 Circuit diagram E0178-321 for P6772-2

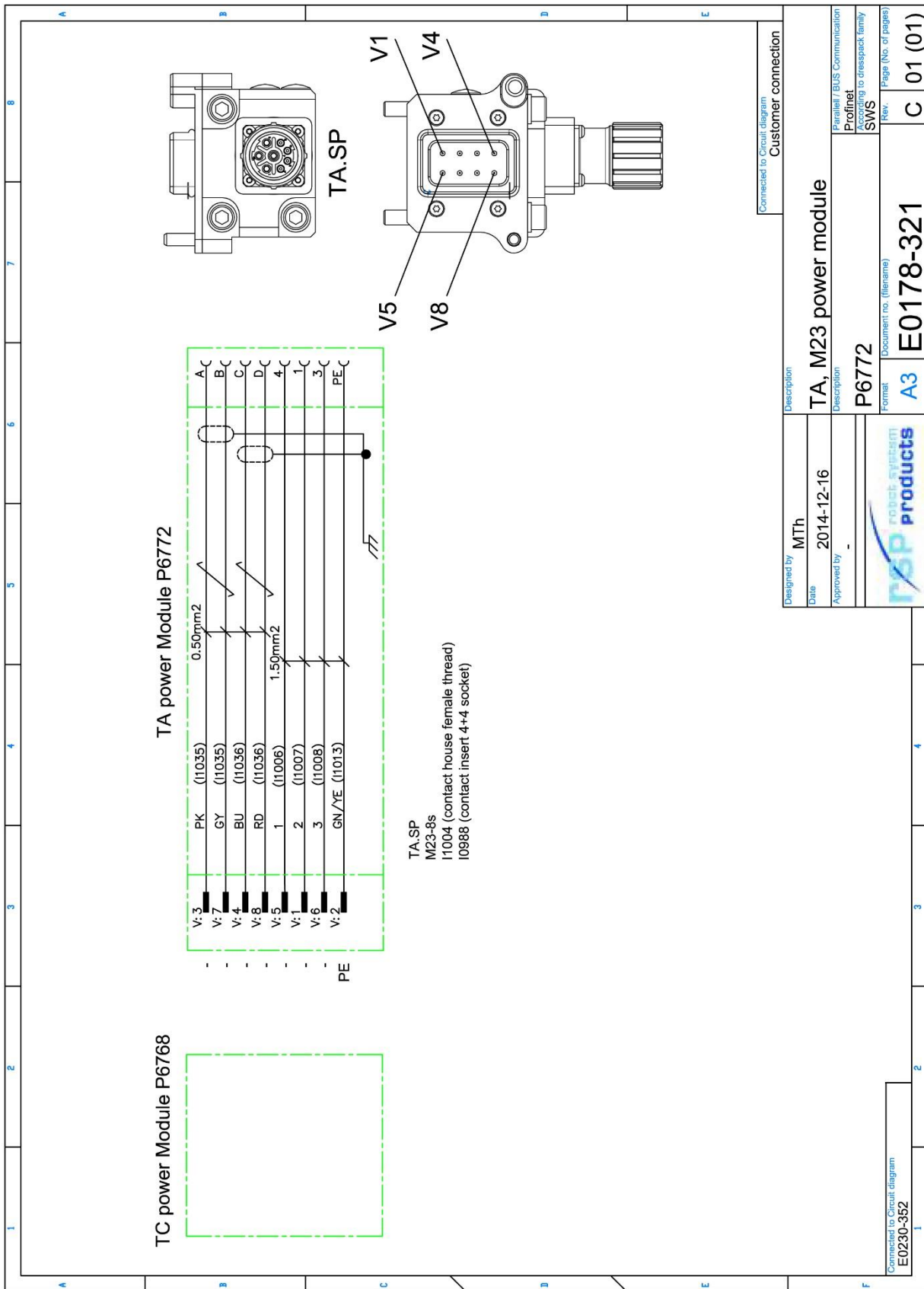

We reserve rights in this document and in the information contained therein.
 It is strictly forbidden to reproduce, disseminate or otherwise use the information without express authority.
 In strictly forbidden to disseminate, modify or otherwise use the information without express authority.

Designed by	MTh	Description	Customer connection
Date	2014-12-16	TA, M23 power module	
Approved by	-	P6772	
		Format	Document no. (filename)
		A3	E0178-321
			C 01 (01)

6.3 Contact cover for Small power modules, tool side. Article: P7263

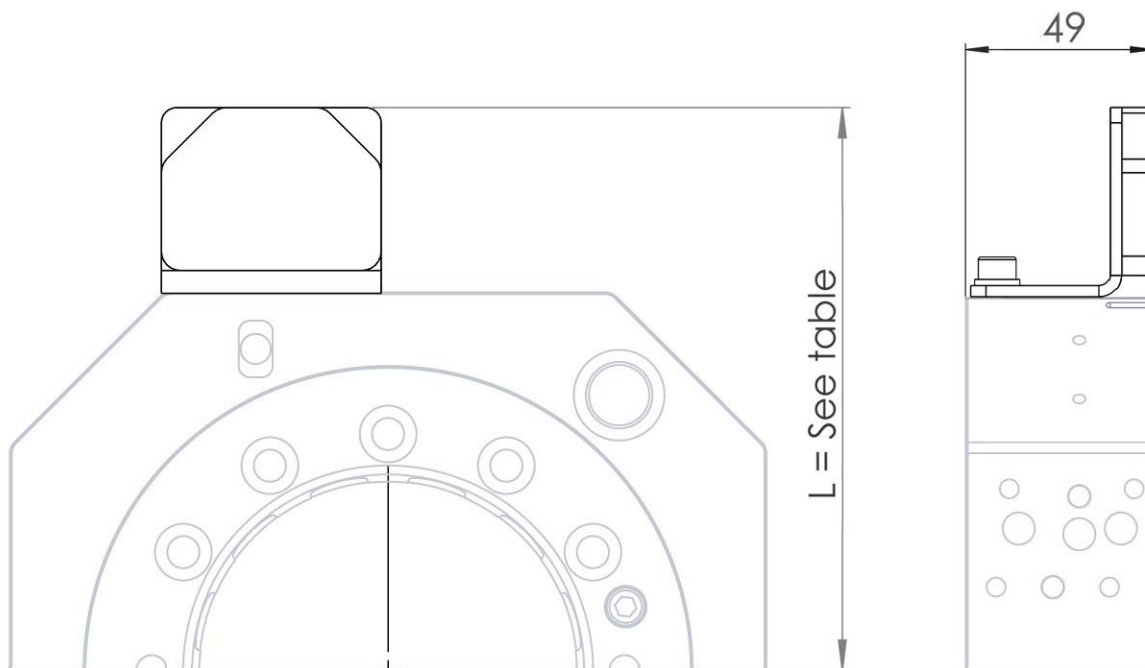

Distance from center of tool attachment (L)		
Tool attachment	Without adapter plate	With adapter plate (P7316)
TA240	149 mm	161 mm
TA480	169 mm	181 mm
TA720	189 mm	201 mm
TA960	224 mm	236 mm

To be mounted on the TA and used together with option P6768-2 on the TC-side when no corresponding Small power module is used on tool attachment.

Technical data

Weight	0.2 kg
--------	--------

7 LARGE MODULES

7.1 Multi-module with Profinet, robot side. Article: P6778

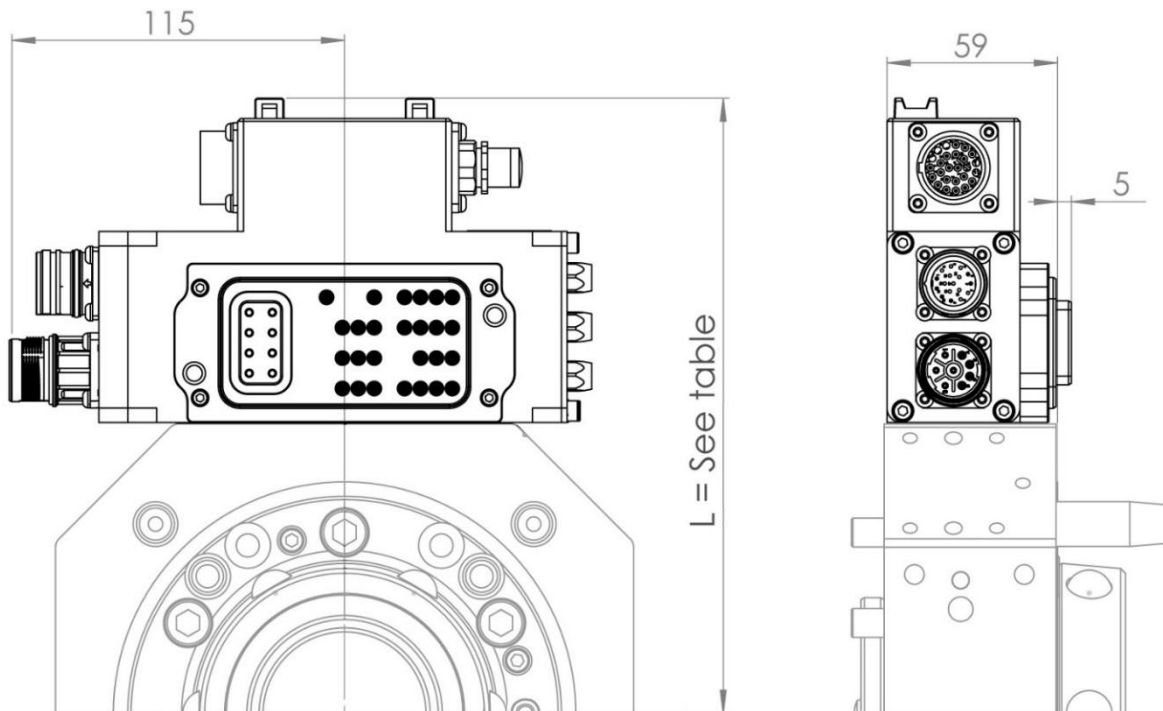

Distance from center of tool changer (L)		
Tool changer	Without adapter plate	With adapter plate (P7323)
TC240	212 mm	224 mm
TC480	232 mm	244 mm
TC720	252 mm	264 mm
TC960	287 mm	299 mm

Multi-module P6778 transfers 19 electrical signals, 7 servo power signals and 4 field bus signals to the tool attachment. To be mounted on the tool changer and used together with option P6779 to the TA. On the housing 3 separate M8-contacts are mounted, for connecting magnetic sensors P6789, P7173, P7174, P7293 or P7175 and Integrated valves P6718 or P7710.

Technical data

Weight		1.1 kg
Electrical signals	Circuit diagram Compact Souriau 26P (UT0W01626PH) Dedicated signals, 3 x M8 3S	E0230-290 (section 7.1.1) 19 x (2A, 30V) + PE 24V (sensors), 0V (valves and sensors), TC Opened and TC Closed (sensors), doOpen TC 1 and doOpen TC 2 (valves)
	M23 17P (7410 000 000, 7003 917 101)	6 x (2A, 60V)
Servo power	M23 8P (7601 000 000, 7084 943 101)	4 x (5A, 300V) + 3 x (15A, 600V) + PE
Field bus	Field bus type M12 4S D-coded	Profinet, Ethernet, EtherCAT 4 (2 pairs) field bus channels, 100 Mbit/s
Connection kits (optional)	P8025 (signals) P8029 (signals) P8030 (power) I1175 (field bus)	Compact Souriau 26S (straight) M23 17S (straight) M23 8S (straight) M12 4P D-coded

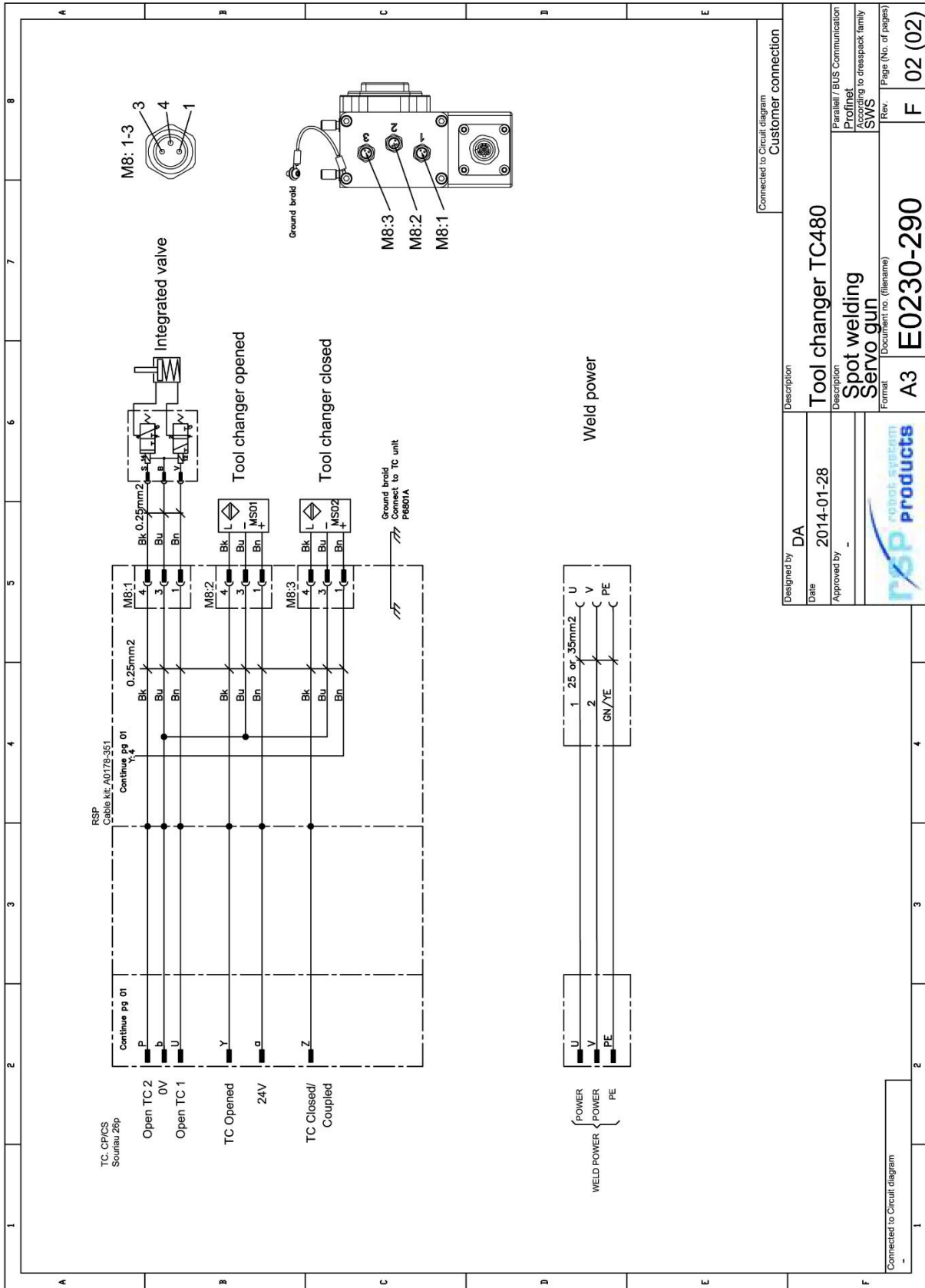

We reserve rights in this document and in the information contained therein. Reproduction, use or disclosure to third parties without express authority is strictly forbidden. Robot System Products

7.2 Multi-module with Profinet, tool side. Article: P6779

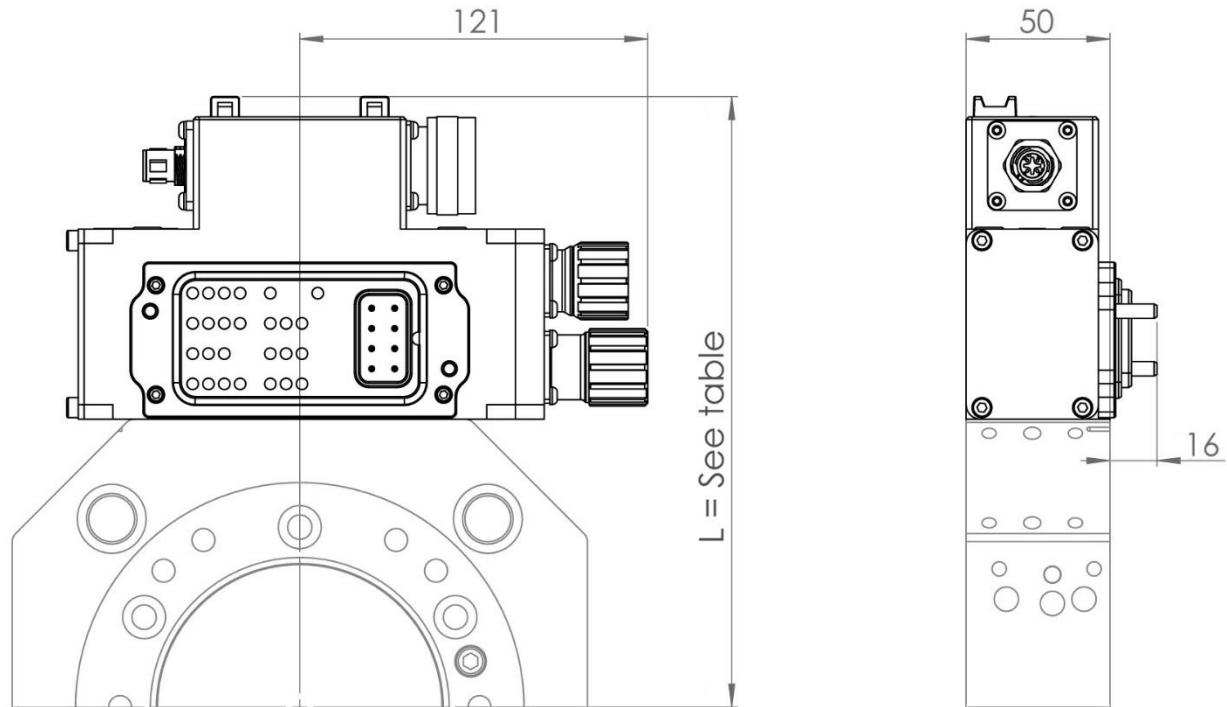

Distance from center of tool attachment (L)		
Tool attachment	Without adapter plate	With adapter plate (P7324)
TA240	212 mm	224 mm
TA480	232 mm	244 mm
TA720	252 mm	264 mm
TA960	287 mm	299 mm

Multi-module P6779 transfers 19 electrical signals, 7 servo power signals and 4 field bus signals to the tool. To be mounted at the tool attachment and used together with option P6778 attached to the tool changer.

Technical data

Weight		1.1 kg
Electrical signals	Circuit diagram Compact Souriau 26S (UT0W61626SH) M23 17S (7440 000 000, 7003 917 102)	E0230-291 (section 7.2.1) 13 signals + PE 6 signals
Servo power	M23 8S (7641 000 000, 7084 943 102)	7 signals + PE
Field bus	Field bus type M12 4P D-coded	Profinet, Ethernet, EtherCAT 4 (2 pairs) field bus channels
Connection kits (optional)	P8022 (signals) P8031 (signals) P8032 (power) I1257 (field bus)	Compact Souriau 26P (straight) M23 17P (straight) M23 8P (straight) M12 4S D-coded

7.3 Signal and bus module, robot side. Article: P6780

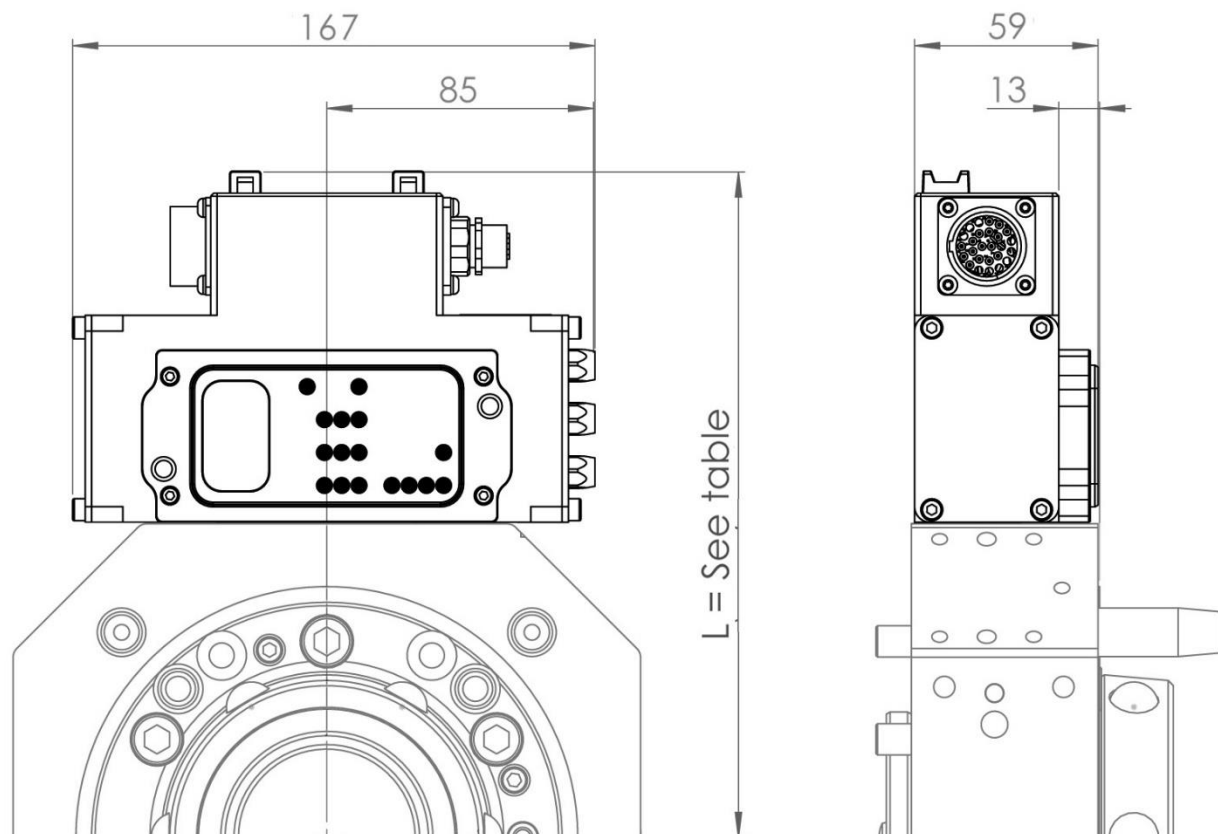

Distance from center of tool changer (L)		
Tool changer	Without adapter plate	With adapter plate (P7323)
TC240	212 mm	224 mm
TC480	232 mm	244 mm
TC720	252 mm	264 mm
TC960	287 mm	299 mm

Signal and bus module P6780 transfers 9 electrical signals and 4 field bus signals to the tool attachment. To be mounted on the tool changer and used together with option P6781 attached to the tool attachment. On the housing 3 separate M8-contacts are mounted, for connecting magnetic sensors P6789, P7173, P7174, P7293 or P7175 and Integrated valves P6718 or P7710.

Technical data

Weight		1.1 kg
Electrical signals	Circuit diagram Compact Souriau 26P (UT0W01626PH) Dedicated signals, 3 x M8 3S	E0230-292 (section 7.3.1) 9 x (2A, 30V) + PE 24V (sensors), 0V (valves and sensors), TC Opened and TC Closed (sensors), doOpen TC 1 and doOpen TC 2 (valve).
Field bus	Field bus type M12 4S D-coded	Profinet, Ethernet, EtherCAT 4 (2 pairs) field bus channels, 100 Mbit/s
Connection kits (opt.)	P8025 (signals) I1175 (field bus)	Compact Souriau 26S (straight) M12 4P D-coded

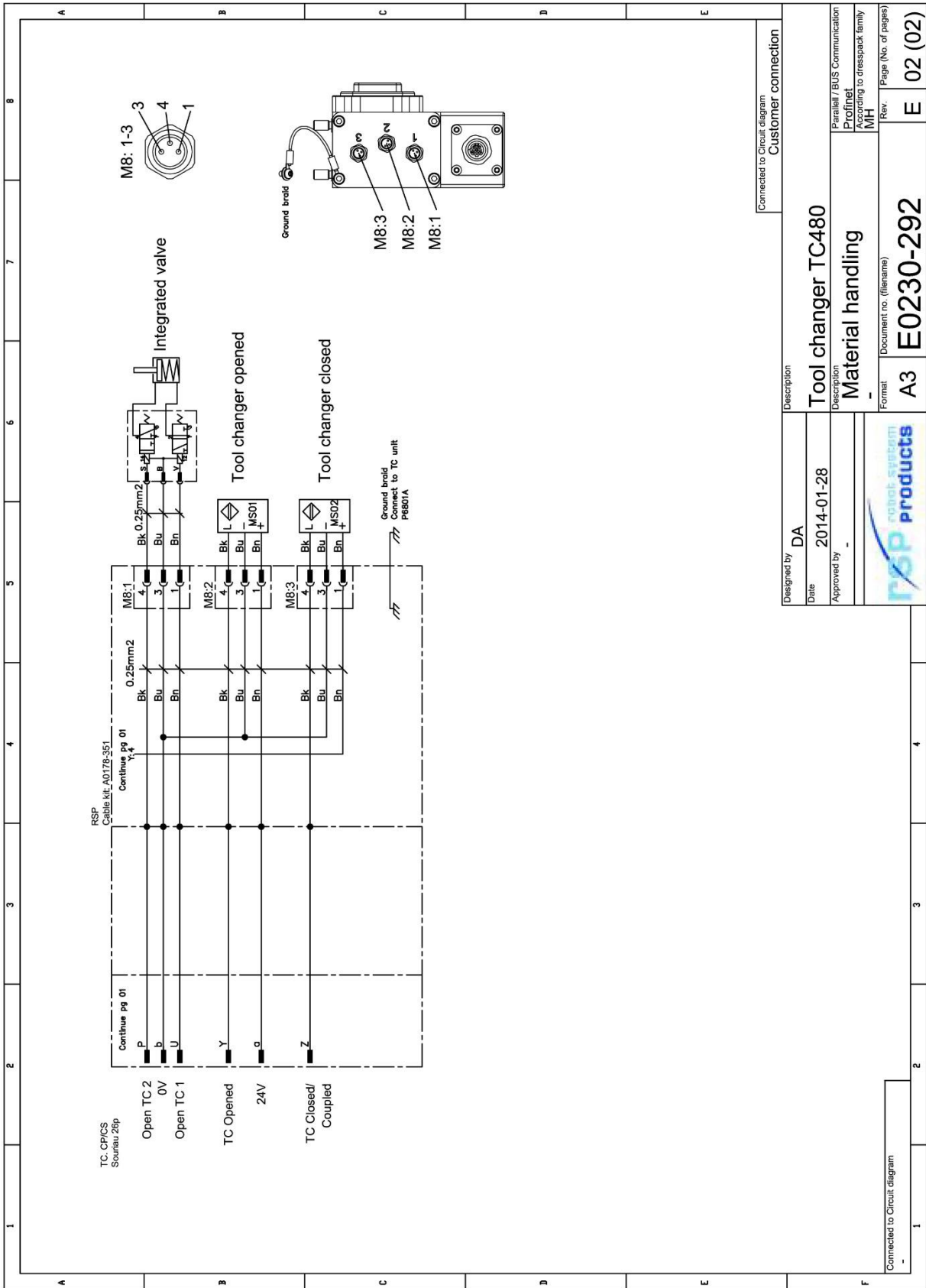

We reserve rights in this document and in the information contained therein. Reproduction, use or disclosure to third parties without express authority is strictly forbidden. Robot System Products

Designed by		DA	
Date		2014-01-28	
Approved by			
Description		Tool changer TC480	
Description		Material handling	
Format		A3	
Document no. (filename)		E0230-292	
Rev.		E	
Page (No. of pages)		02 (02)	

Connected to Circuit diagram
Customer connection

Connected to Circuit diagram



7.4 Signal and bus module, tool side. Article: P6781

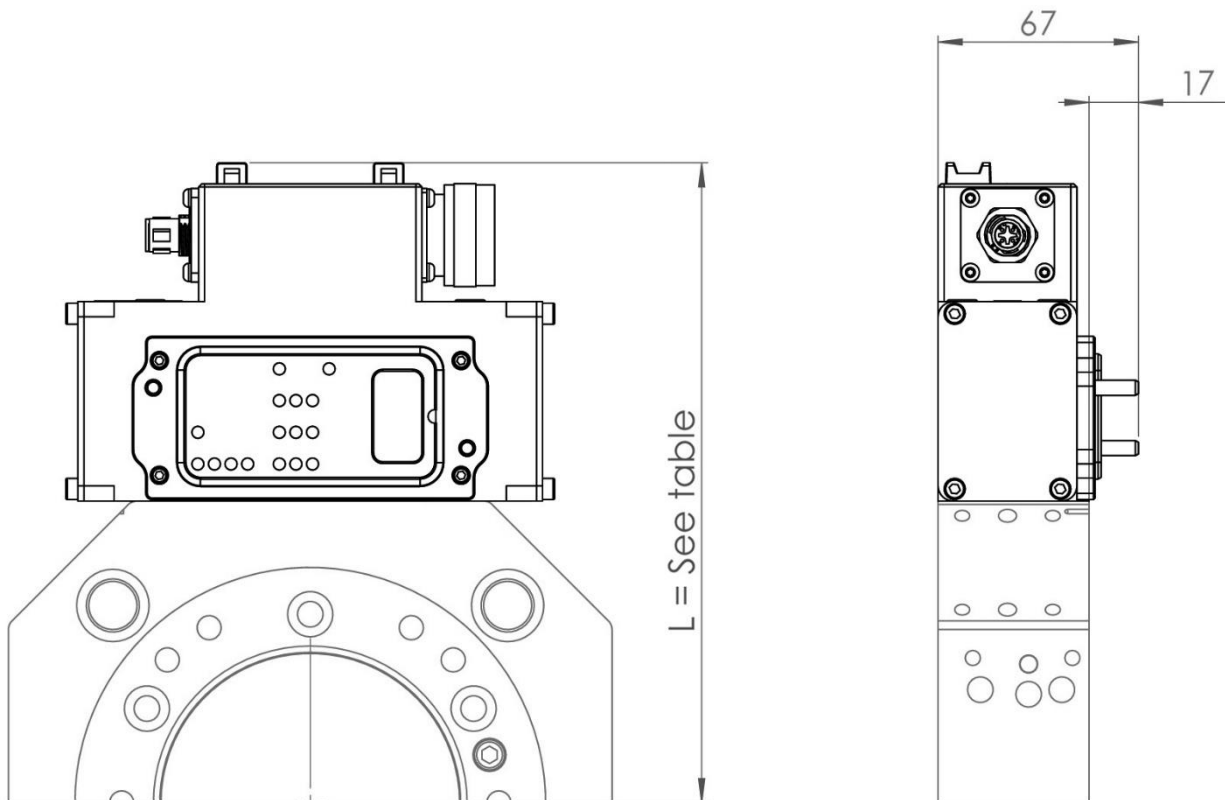

Distance from center of tool attachment (L)

Tool attachment	Without adapter plate	With adapter plate (P7324)
TA240	212 mm	224 mm
TA480	232 mm	244 mm
TA720	252 mm	264 mm
TA960	287 mm	299 mm

Signal and bus module P6781 transfers 9 electrical signals and 4 field bus signals to the tool. To be mounted at the tool attachment and used together with option P6780 attached to the tool changer.

Technical data

Weight		1.0 kg
Electrical signals	Circuit diagram Compact Souriau 26S (UT0W61626SH)	E0230-293 (section 7.4.1) 9 signals + PE
Field bus	Field bus type M12 4P D-coded	Profinet, Ethernet, EtherCAT 4 (2 pairs) field bus channels
Connection kits (optional)	P8022 (connector) I1257 (field bus)	Compact Souriau 26P (straight) M12 4S D-coded

7.4.1 Circuit diagram E0230-293 for P6781

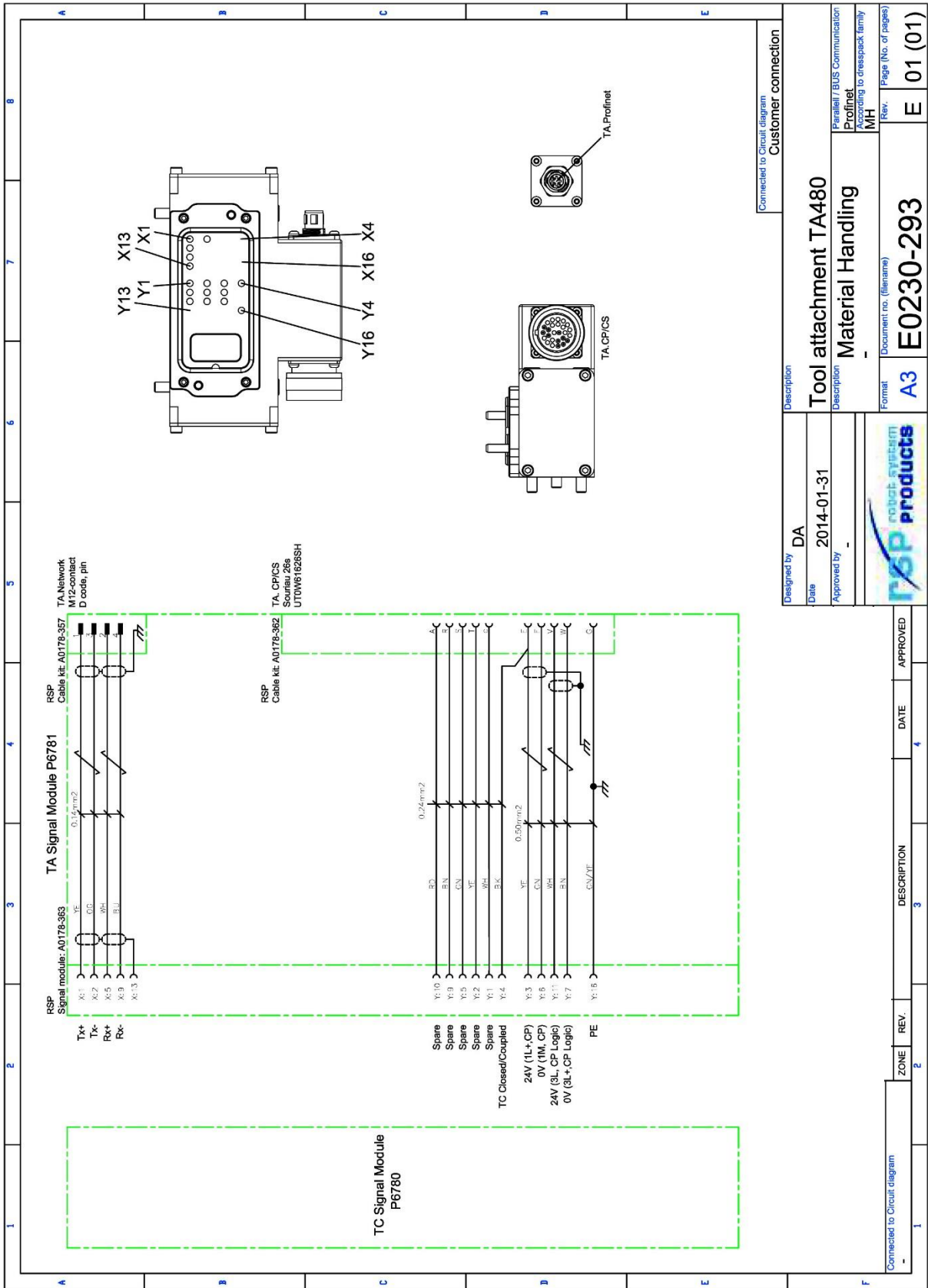

We reserve rights in this document and in the information contained therein. Reproduction use or disclosure to third parties without express authority is strictly forbidden. Robot System Products

Designed by	DA	Description	Connected to Circuit diagram
Date	2014-01-31		
Approved by	-	Tool attachment TA480	
		Material Handling	
		Parallel/ BUS Communication	
		Profinet	
		According to cresspack family	
		MH	
		Rev. Page (No. of pages)	
		E 01 (01)	
		Document no. (filename)	
		E0230-293	
		Format	
		A3	

DESIGNATION	3	DATE	4	APPROVED
ZONE	2	REV.		
Connected to Circuit diagram				

7.5 Signal and power module (ABB compatible), robot side. Article: P7291

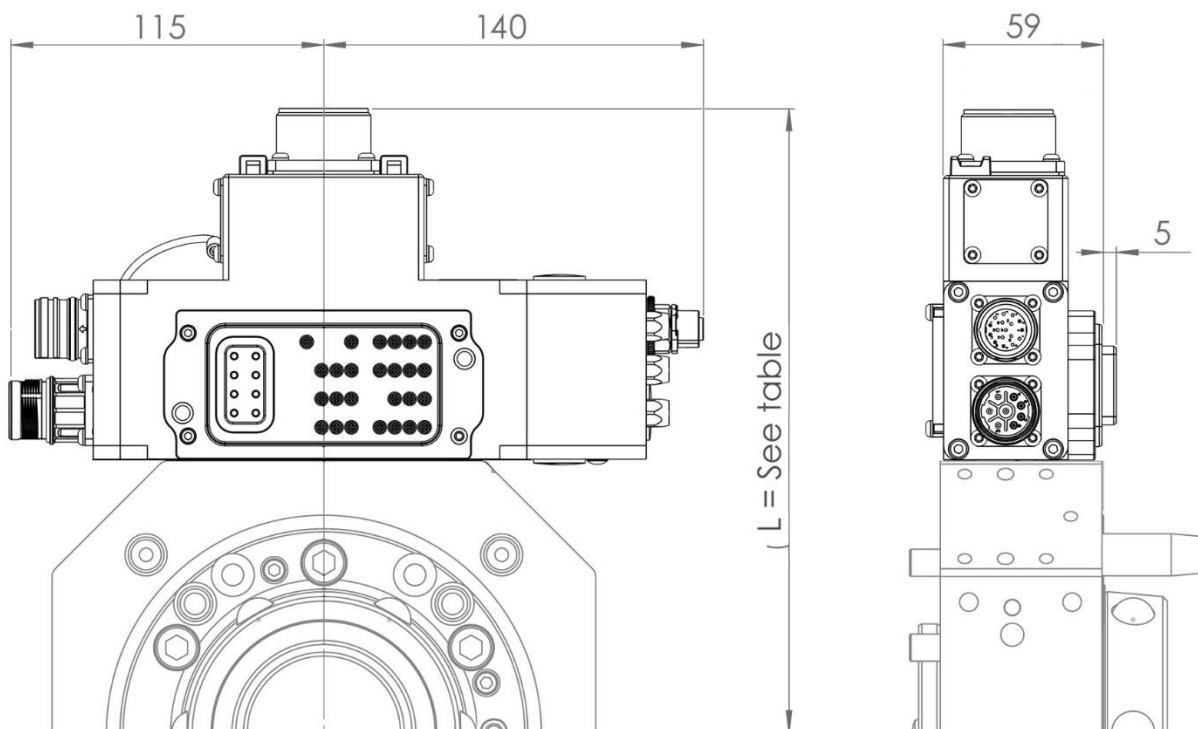

Distance from center of tool changer (L)		
Tool changer	Without adapter plate	With adapter plate (P7323)
TC240	230 mm	242 mm
TC480	250 mm	262 mm
TC720	270 mm	282 mm
TC960	305 mm	317 mm

Signal and power module P7291 transfers 11 electrical signals and 7 servo power signals to the tool attachment. To be mounted on the tool changer and used together with option P7292 at the TA. On the housing 3 separate M8-contacts are mounted, for connecting magnetic sensors P6789, P7173, P7174, P7293 or P7175 and Integrated valves P6718 or P7710.

Technical data

Weight		1.1 kg
Electrical signals	Circuit diagram	E0178-862 (section 7.5.1)
	Amphenol MS3102A 22-19P	4xTool_ID, TA_present, 0V, 24V, 2 x (2A, 30V) + PE
	M23 17P (7410 000 000, 7003 917 101)	6 x (2A, 60V)
	Dedicated signals, 3 x M8 3S	24V (sensors), 0V (valves and sensors), TC Opened and TC Closed (sensors), doOpen TC 1 and doOpen TC 2 (valve).
	M12 5S, A-coded	TC_Empty sensor (for sensor)
Servo power	M23 8P (7601 000 000, 7084 943 101)	4 x (5A,300V) + 3 x (15A,600V) + PE

7.5.1 Circuit diagram E0178-862 for P7291 and P7292

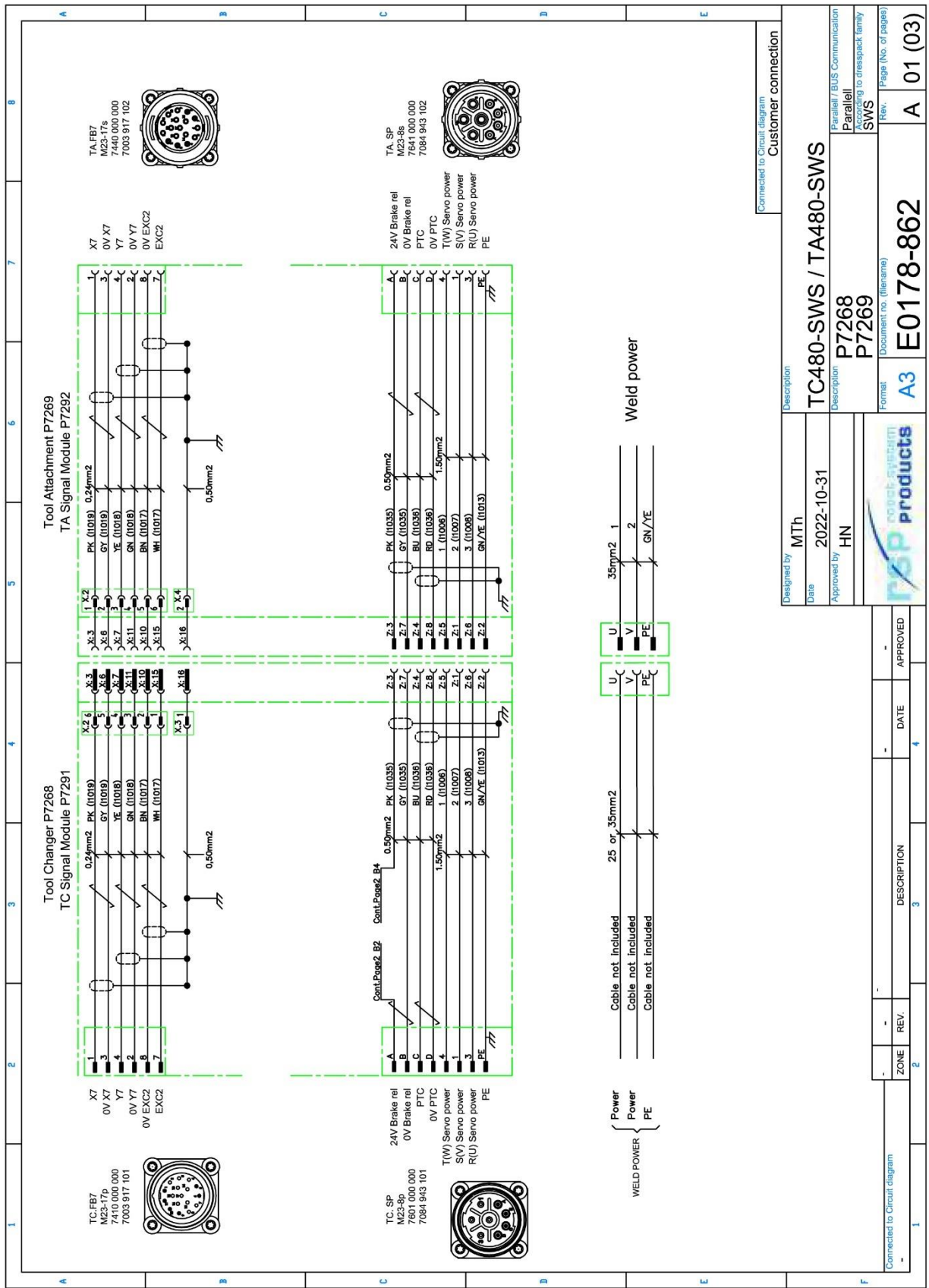

Designed by	MTH	Description	TC480-SWS / TA480-SWS
Date	2022-10-31	Description	P7268
Approved by	HN	Description	P7269
Format	Document no. (filename)	Format	Document no. (filename)
Rev.	A	Rev.	A
Page (No. of pages)	01 (03)	Page (No. of pages)	01 (03)



ZONE	REV.	DESCRIPTION	DATE	APPROVED
1	-	-	-	-
2	-	-	-	-
3	-	-	-	-

We reserve rights in this document and in the information contained therein. Reproduction or disclosure to third parties without express authority is strictly prohibited. RSP products

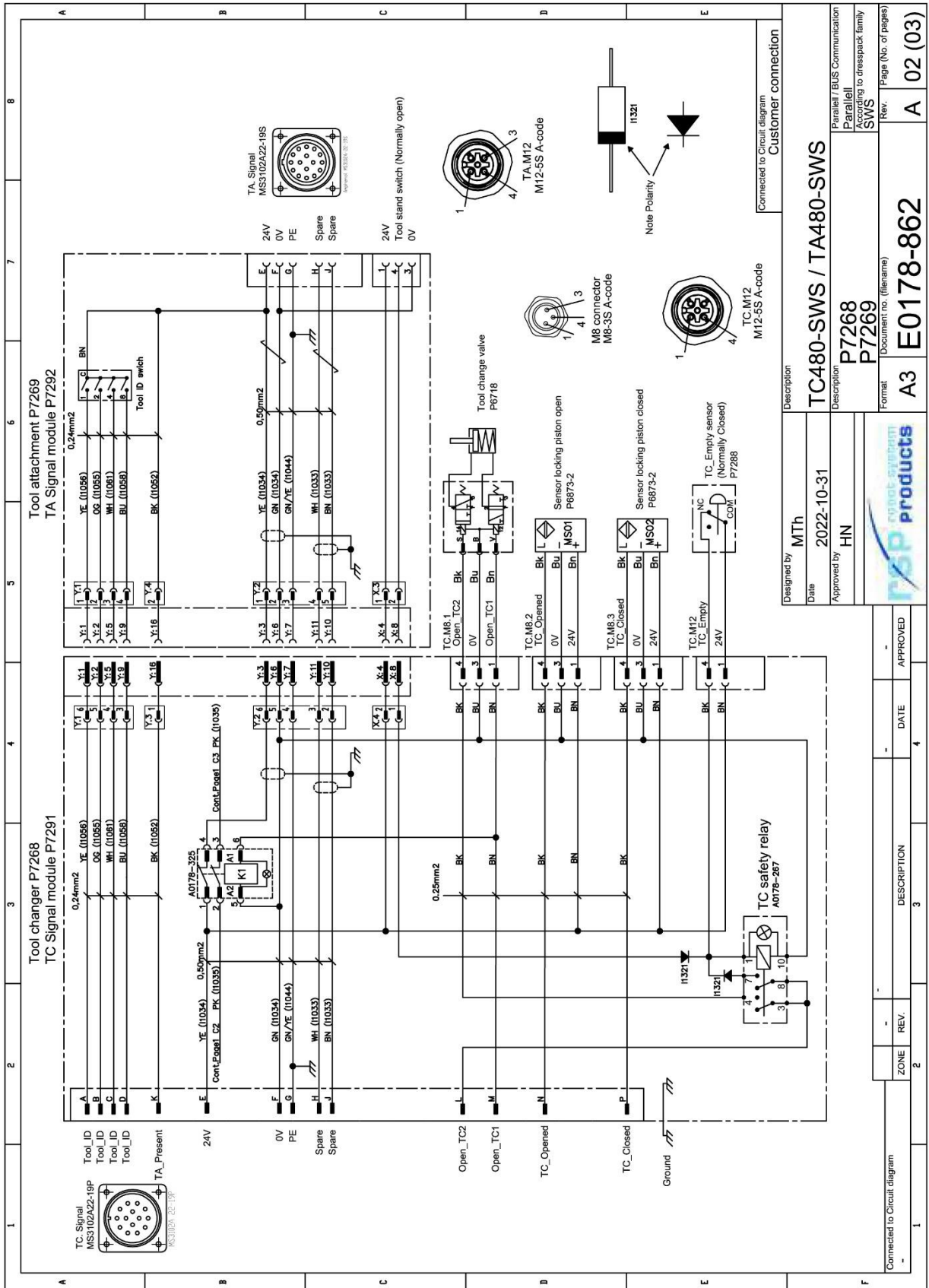

We reserve rights in this document and in the information contained therein. It is strictly forbidden to reproduce or disclose to third parties without express authority.

Designed by	MTh
Date	2022-10-31
Approved by	HN
Description	TC480-SWS / TA480-SWS
Description	P7268 P7269
Format	A3
Document no. (filename)	E0178-862
Rev.	A
Page No. of pages	02 (03)

ZONE	REV.	DATE	DESCRIPTION
1	-	-	APPROVED

Connected to Circuit diagram
Customer connection

Connected to Circuit diagram
Customer connection

Connected to Circuit diagram
Customer connection

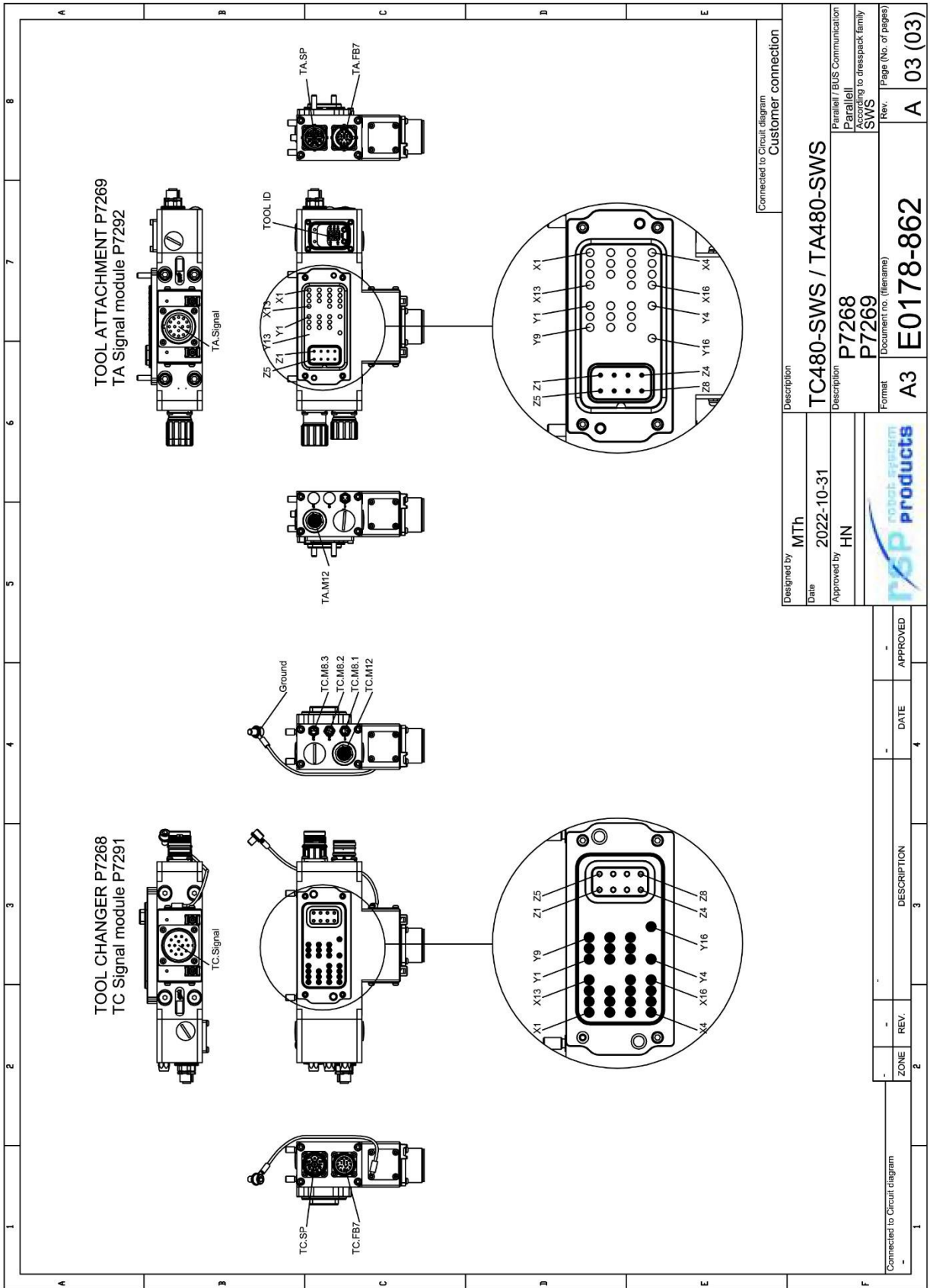

We reserve rights in this document and in the information contained therein. Reproduction, use or disclosure to third parties without express authority is strictly forbidden. Robot System Products

**7.6 Signal and power module (ABB compatible), tool side.
Article: P7292**

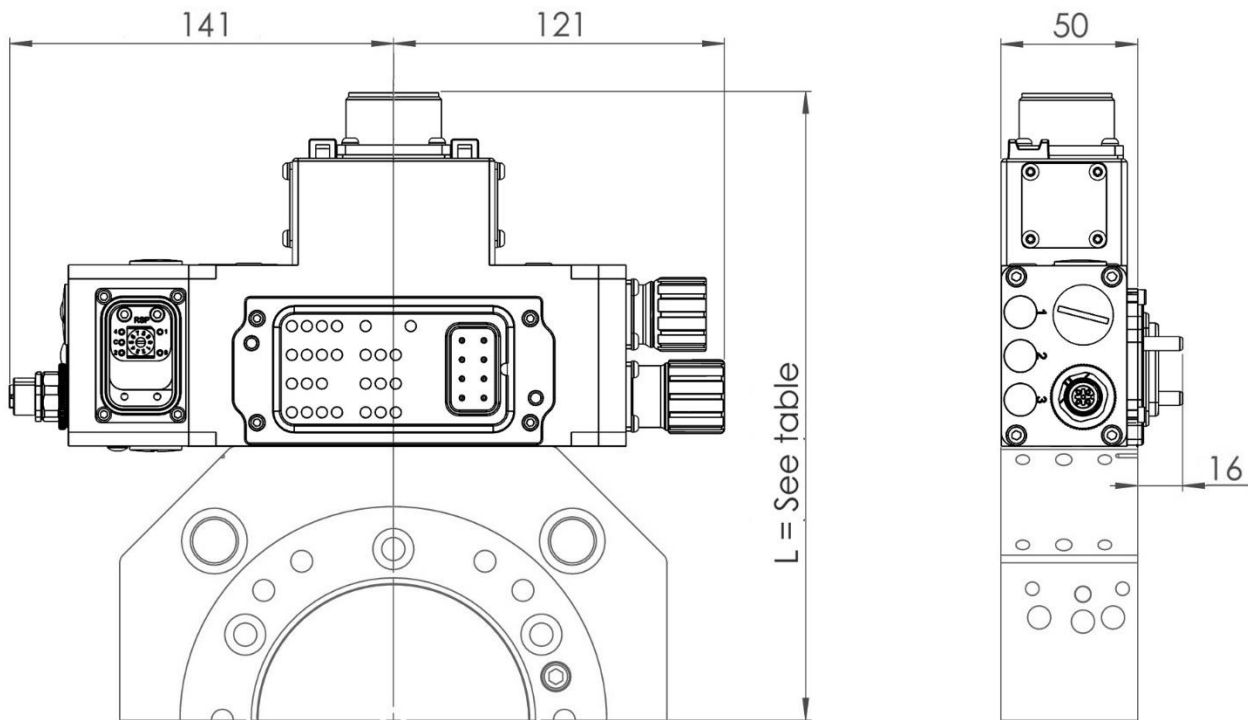

Distance from center of tool attachment (L)		
Tool attachment	Without adapter plate	With adapter plate (P7324)
TA240	230 mm	242 mm
TA480	250 mm	262 mm
TA720	270 mm	282 mm
TA960	305 mm	317 mm

Signal and power module P7292 transfers 14 electrical signals and 7 servo power signals to the tool. To be mounted at the tool attachment and used together with option P7291 attached to the tool changer.

Technical data

Weight		1.1 kg
Electrical signals	Circuit diagram	E0178-862 (section 7.5.1)
	Amphenol MS3102A 22-19S	4 x signals + PE
	M23 17S (7440 000 000, 7003 917 102)	6 signals
	M12 5S, A-coded	Tool in stand signal (for sensor)
Servo power	M23 8S (7641 000 000, 7084 943 102)	7 power signals + PE

7.7 Signal and power module (Yaskawa compatible), robot side.
Article: P7289

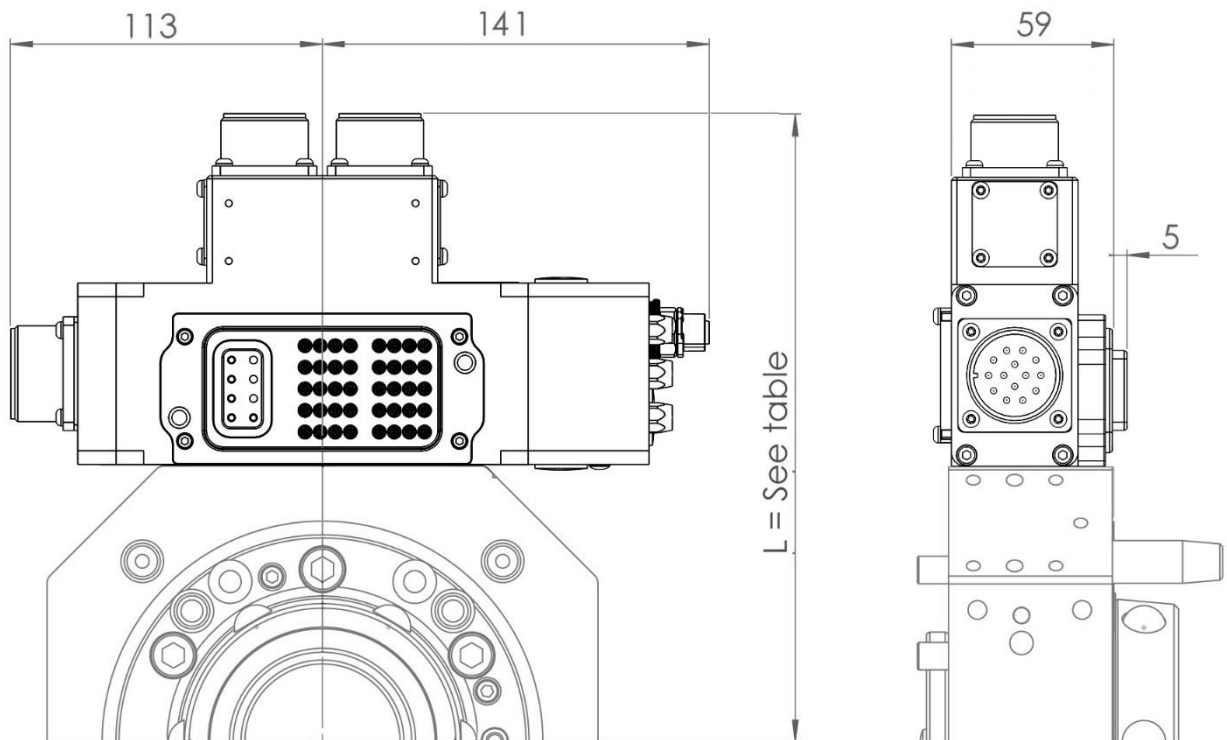

Distance from center of tool changer (L)		
Tool changer	Without adapter plate	With adapter plate (P7323)
TC240	228 mm	240 mm
TC480	248 mm	260 mm
TC720	268 mm	280 mm
TC960	303 mm	315 mm

Signal and power module P7289 transfers 20 electrical signals and 5 servo power signals to the tool attachment. To be mounted on the tool changer and used together with option P7290 at the tool attachment. On the housing 3 separate M8-contacts are mounted, for connecting magnetic sensors P6789, P7173, P7174, P7293 or P7175 and Integrated valves P6718 or P7710.

Technical data

Weight		1.1 kg
Electrical signals	Circuit diagram	E0178-860 (section 7.7.1)
	Amphenol MS3102A 22-19P	4xTool_ID, TA_present, 0V, 24V, 2 x (2A, 30V) + PE
	Amphenol MS3202A 20-29P	12 x (2A, 60V)
	Dedicated signals, 3 x M8 3S	24V (sensors), 0V (valves and sensors), TC Opened and TC Closed (sensors), doOpen TC 1 and doOpen TC 2 (valve).
Servo power	Amphenol MS3102A 20-15P	5 x (15A, 600V) + 2 x PE

7.7.1 Circuit diagram E0178-860 for P7289 and P7290

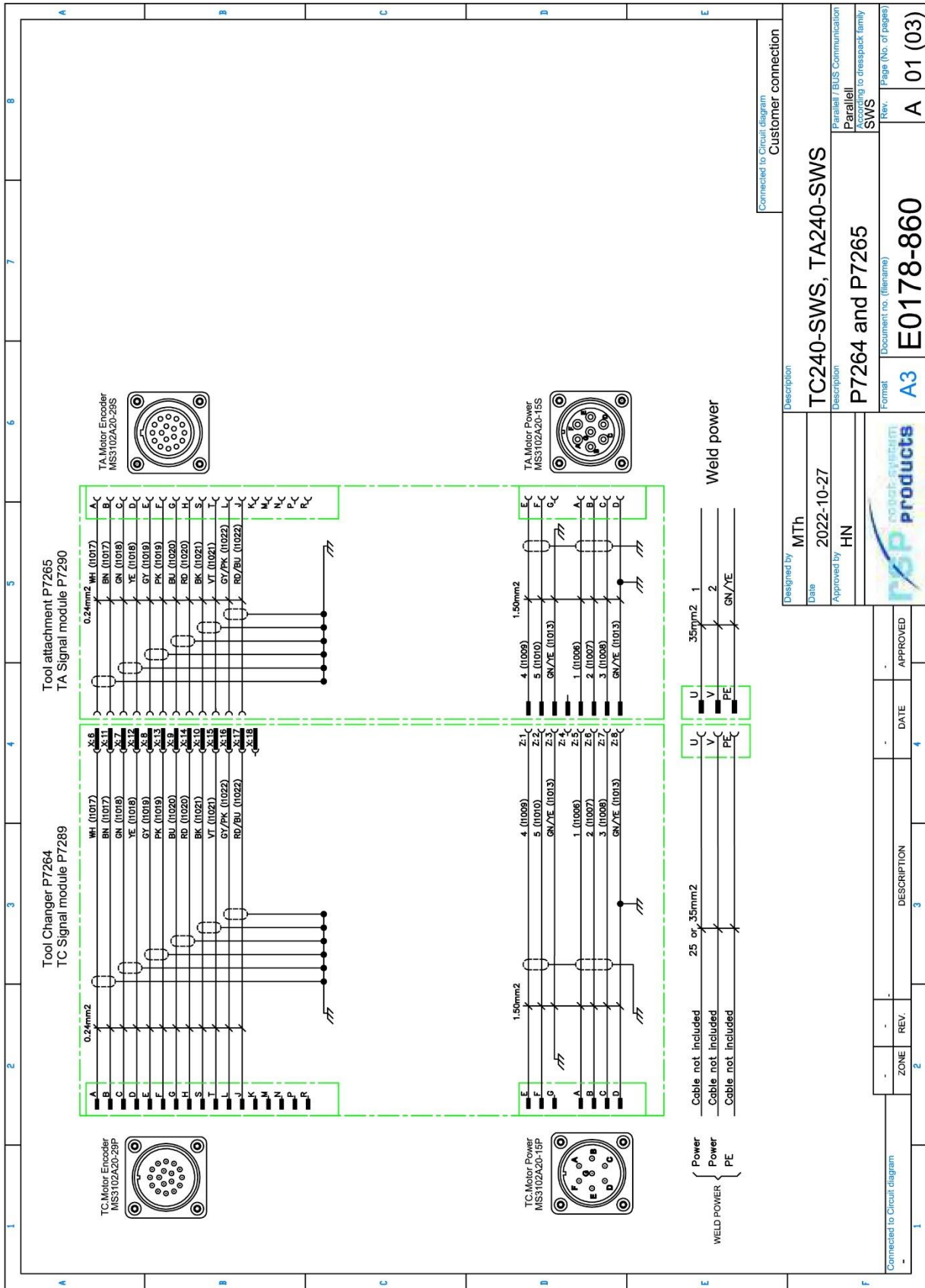

We reserve rights in this document and in the information contained therein. In strictly confidential. Must not be disclosed to third parties without express authority.

Designed by MTh		Description TC240-SWS, TA240-SWS	
Date 2022-10-27		Description P7264 and P7265	
Approved by HN		Format Document no. (if same) A3	
		Parallel BUS Communication Parallel SWS Rev. Page (No. of pages) A 01 (03)	
ZONE	REV.	DESCRIPTION	DATE
1	2	3	4
Connected to Circuit diagram		Customer connection	

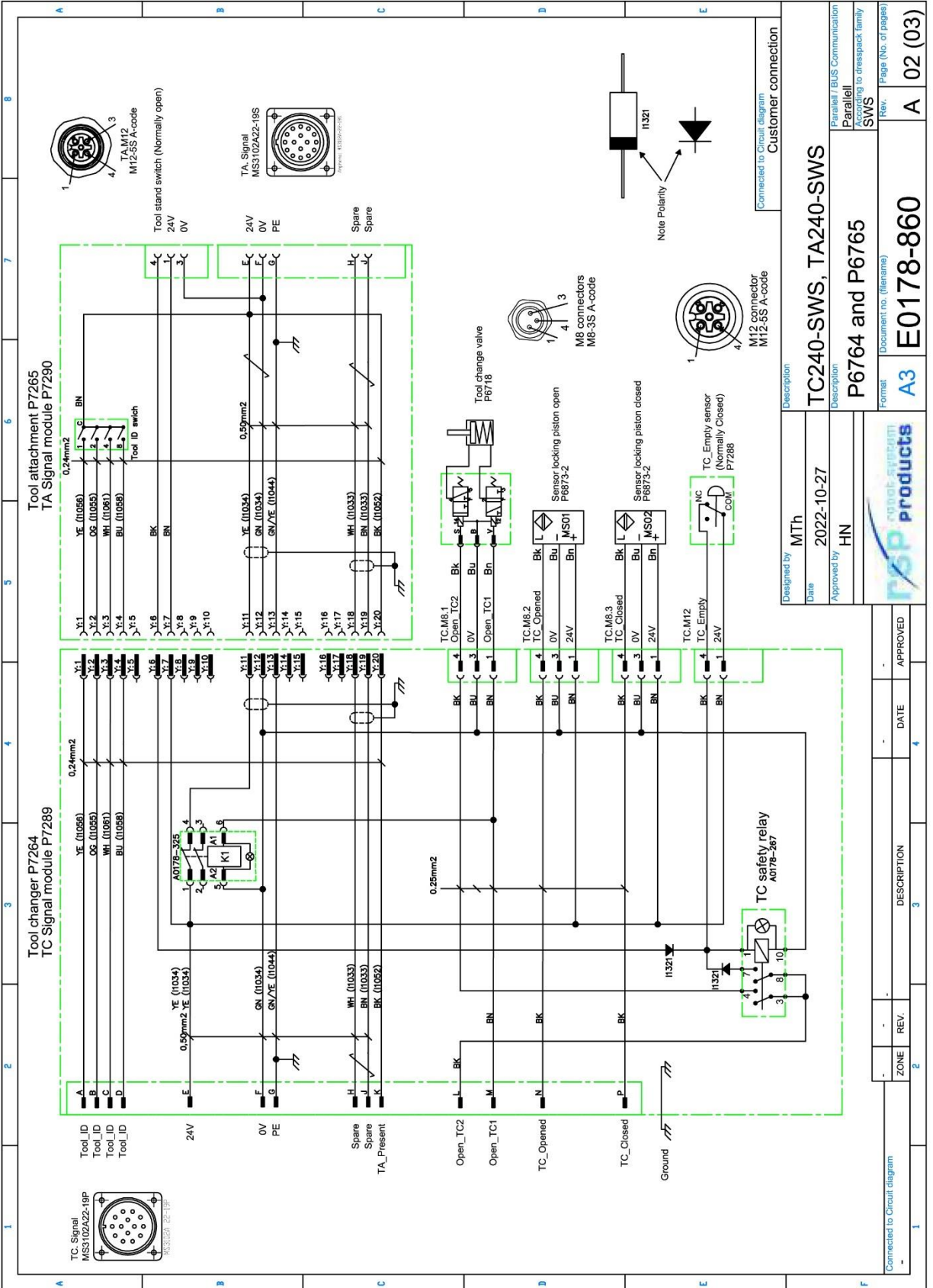

All reserved rights in this document and in the information contained therein
 is strictly forbidden. Robot System Products
 Reproduction use or disclosure to third parties without express authority

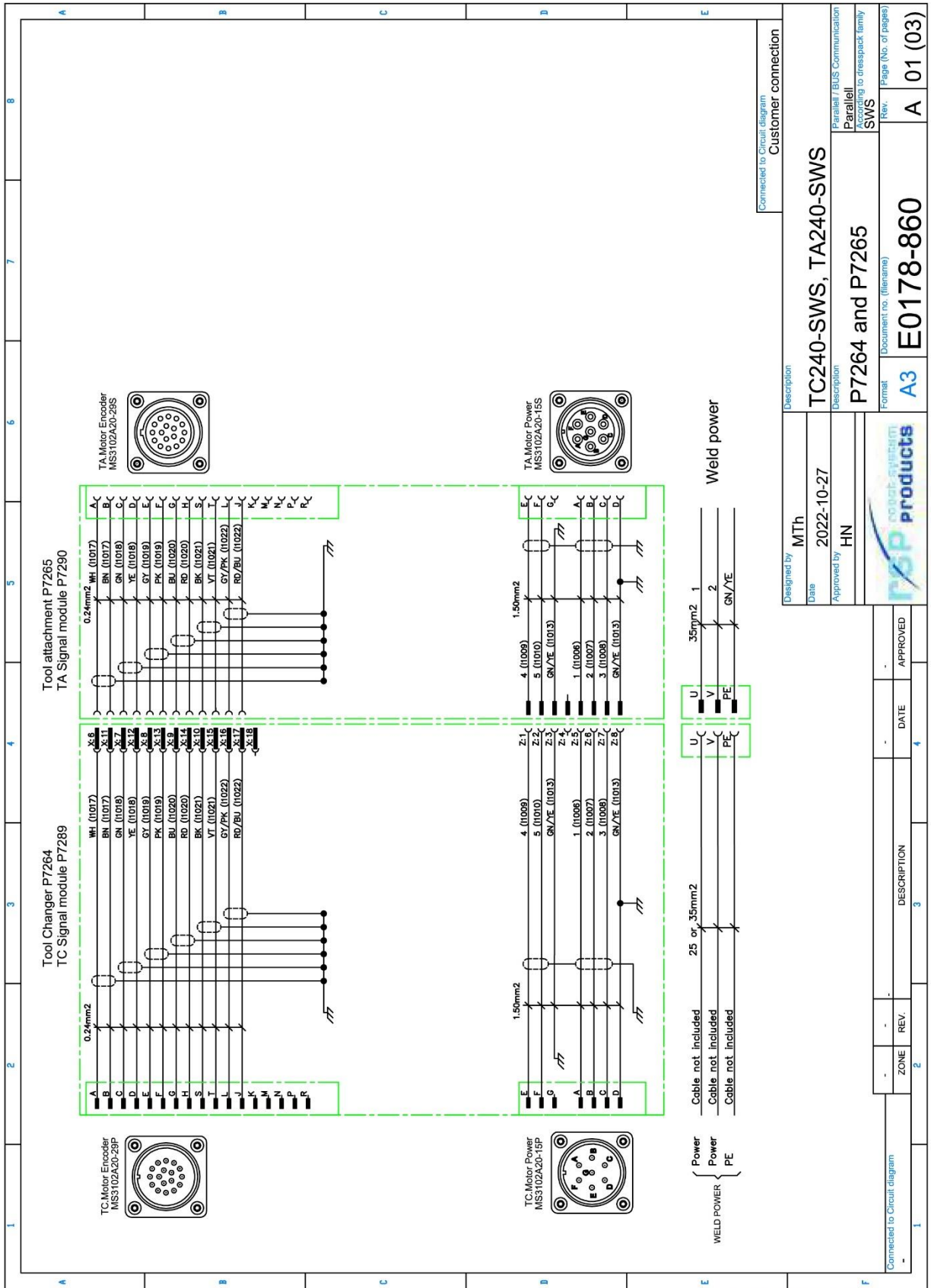

We reserve rights in this document and in the information contained therein. Reproduction, use or disclosure is strictly forbidden, Robot System Products

Designed by	MTh	Description	TC240-SWS, TA240-SWS
Date	2022-10-27	Description	P7264 and P7265
Approved by	HN	Format	A3
		Document no. (filename)	E0178-860
		Rev.	A
		Page (No. of pages)	01 (03)

Zone	REV	DATE	APPROVED
1			
2			
3			



Parallel BUS Communication
 Connecting to cresspart family
 SWS

7.8 Signal and power module (Yaskawa compatible), tool side. Article: P7290

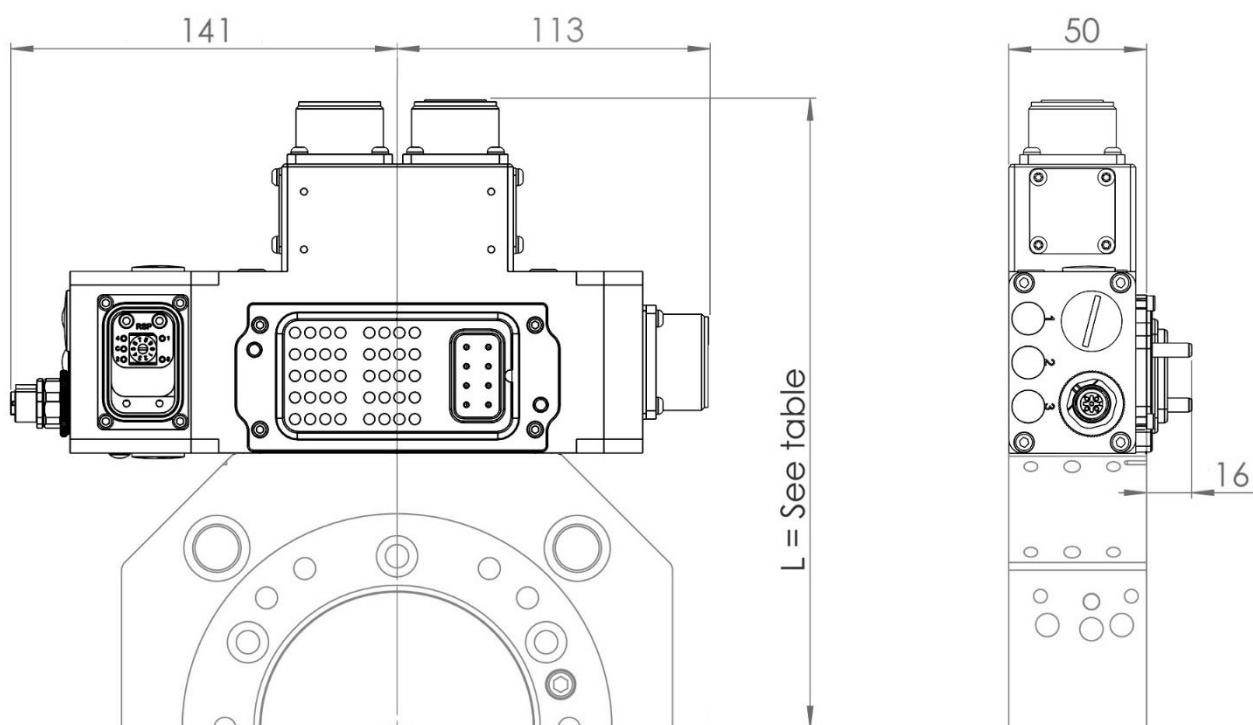

Distance from center of tool attachment (L)		
Tool attachment	Without adapter plate	With adapter plate (P7324)
TA240	228 mm	240 mm
TA480	248 mm	260 mm
TA720	268 mm	280 mm
TA960	303 mm	315 mm

Signal and power module P7290 transfers 14 electrical signals and 5 servo power signals to the tool. To be mounted at the tool attachment and used together with option P7289 attached to the tool changer.

Technical data

Weight		1.1 kg
Electrical signals	Circuit diagram	E0178-860 (section 7.7.1)
	Amphenol MS3102A 22-19S	4 signals + PE
	Amphenol MS3102 20-29S	12 signals
	M12 5S, A-coded	Tool in stand signal (for sensor)
Servo power	Amphenol MS3102A 20-15S	5 power signals + 2 x PE

7.9 Power TC module 8s, base, robot side. Article: P7325

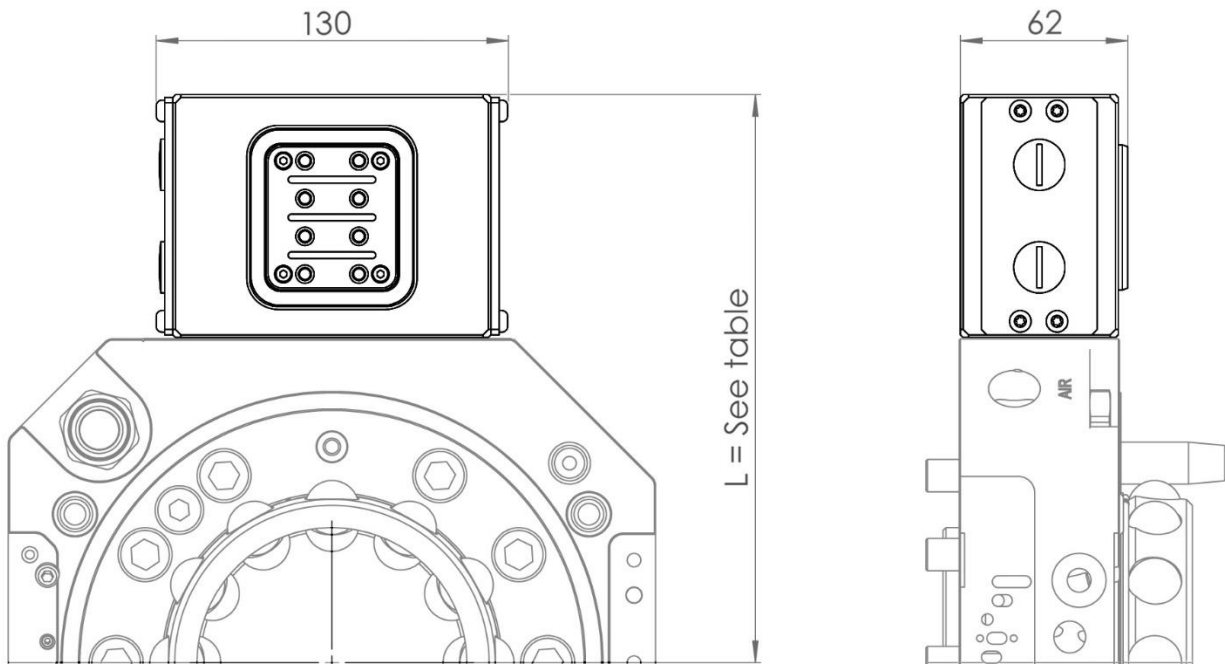

Distance from center of tool changer (L)		
Tool changer	Without adapter plate	With adapter plate (P7323)
TC240	190 mm	202 mm
TC480	210 mm	222 mm
TC720	230 mm	242 mm
TC960	365 mm	277 mm

Generalised power module to be configured by customer. Transfers 8 power signals to the tool attachment. Each pair of pins and sockets are capable of transferring 65 A. To be mounted on the tool changer and used together with P7326.

Technical data

Weight	1.3 kg
Electrical signals	8 Cable lugs Maximum 8 x 65A



NOTE! Connectors will normally reduce maximum current. To utilize the full amperage, connect cables directly using cable lugs!

7.10 Power TA module 8p, base, tool side. Article: P7326

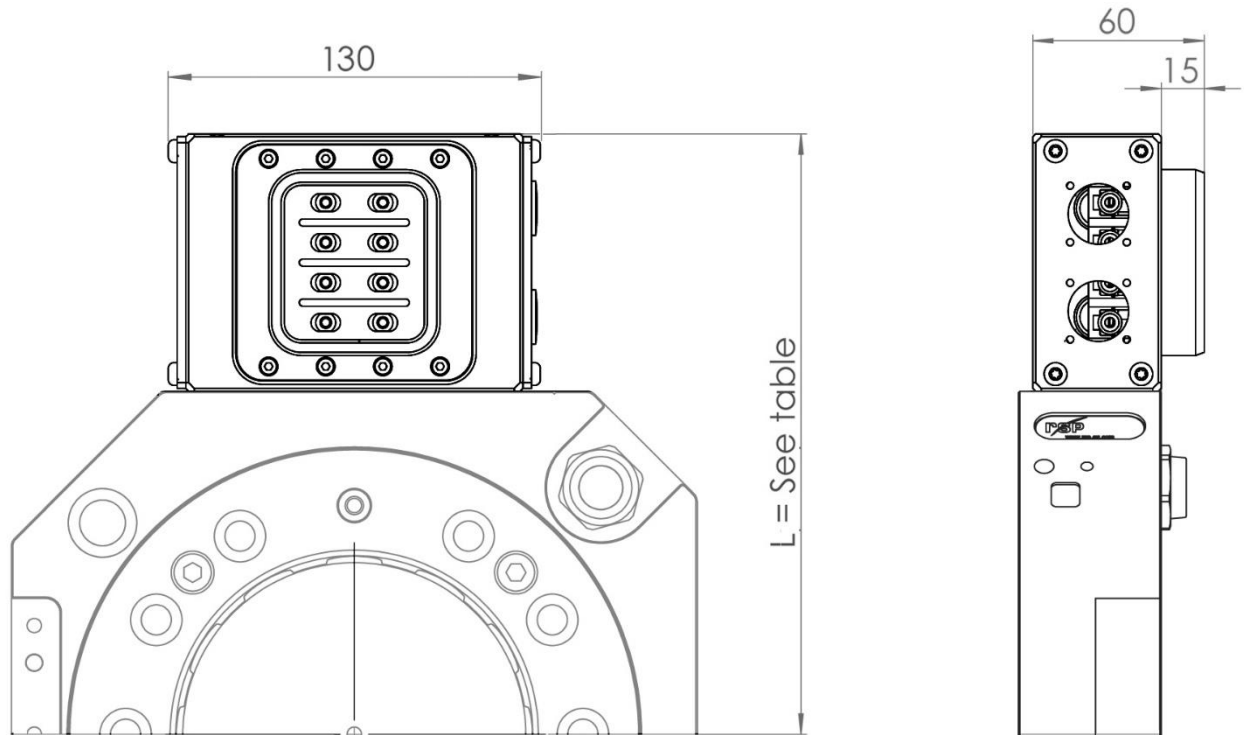

Distance from center of tool attachment (L)		
Tool attachment	Without adapter plate	With adapter plate (P7324)
TA240	190 mm	202 mm
TA480	210 mm	222 mm
TA720	230 mm	242 mm
TA960	365 mm	277 mm

Transfers 8 electrical signals to the tool. To be mounted at the tool attachment and used together with option P7325 attached to the tool changer.

Technical data

Weight		1.3 kg
Electrical signals	8 Cable lugs	Maximum 8 x 65A

7.11 Large module contact cover, tool side. Article: P7249

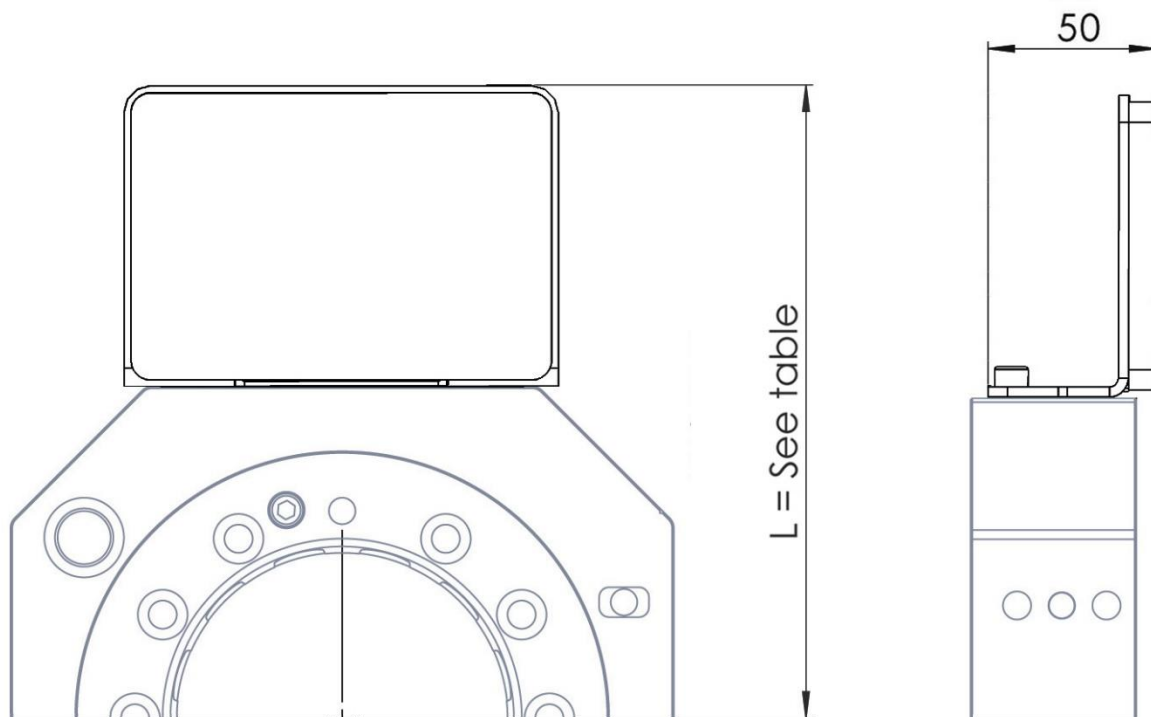

Distance from center of tool attachment (L)		
Tool attachment	Without adapter plate	With adapter plate (P7324)
TA240	190 mm	202 mm
TA480	210 mm	222 mm
TA720	230 mm	242 mm
TA960	365 mm	277 mm

To be used together with options P6778, P6780, P7291, P7289 and P7325 when no large module are used on tool attachment.

Technical data

Weight	0.5 kg
--------	--------

8 WATER AND AIR MODULES

8.1 Water/air coupling, 1–4 channels, robot side. Article: P7318

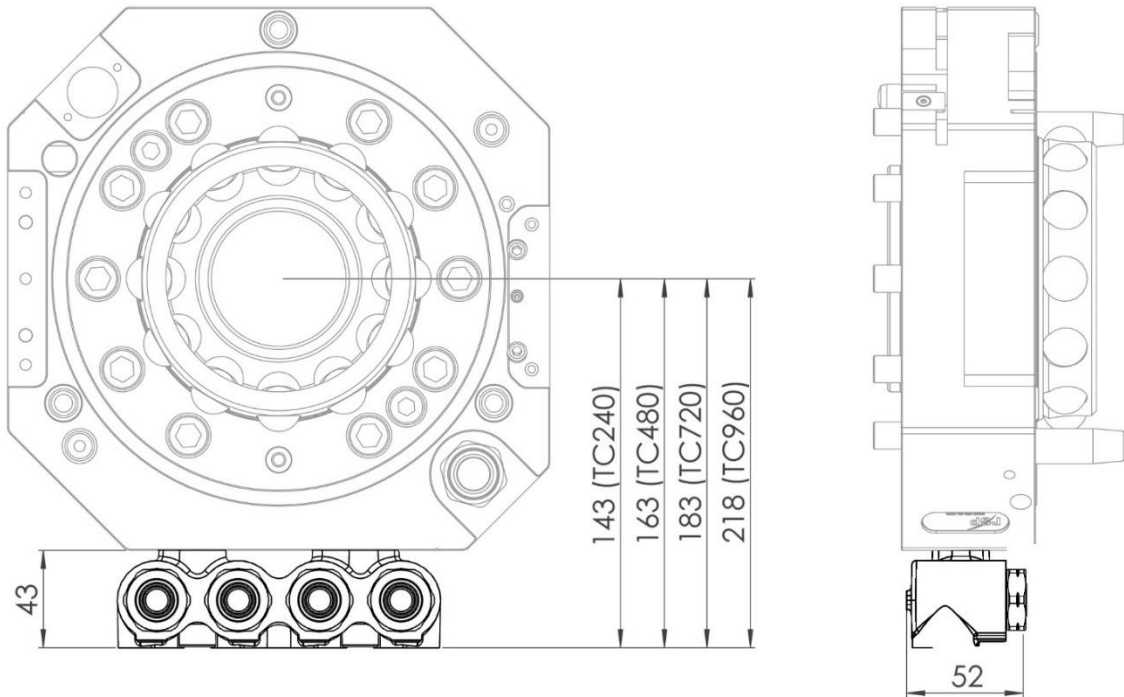

Transfers 1–4 water/air channels, with non-return valves, to the tool attachment. Can be mounted at 2 different positions on the tool changer. To be used together with option P7319 attached to the tool attachment.

Technical data

Weight	1.4–1.6 kg (depending on no. of ducts)	
Water/air channels	Pneumatic diagram	Pne0230-017 (section 8.1.1)
	Water/air connections	1–4 x G $\frac{1}{2}$ " (2000l/min air, max 10 bar)
	Water flow	20 l/min
	Water/air quality	Max 25 μ m particle content

Number of ducts		Article numbers
Water/air channels	1	P7318-1A/1B
	2	P7318-2A/2B
	3	P7318-3A/3B/3C
	4	P7318-4A
Configuration of water/air couplings		A0230-627 (section 8.1.2)

8.1.1 Pneumatic diagram, Pne0230-017

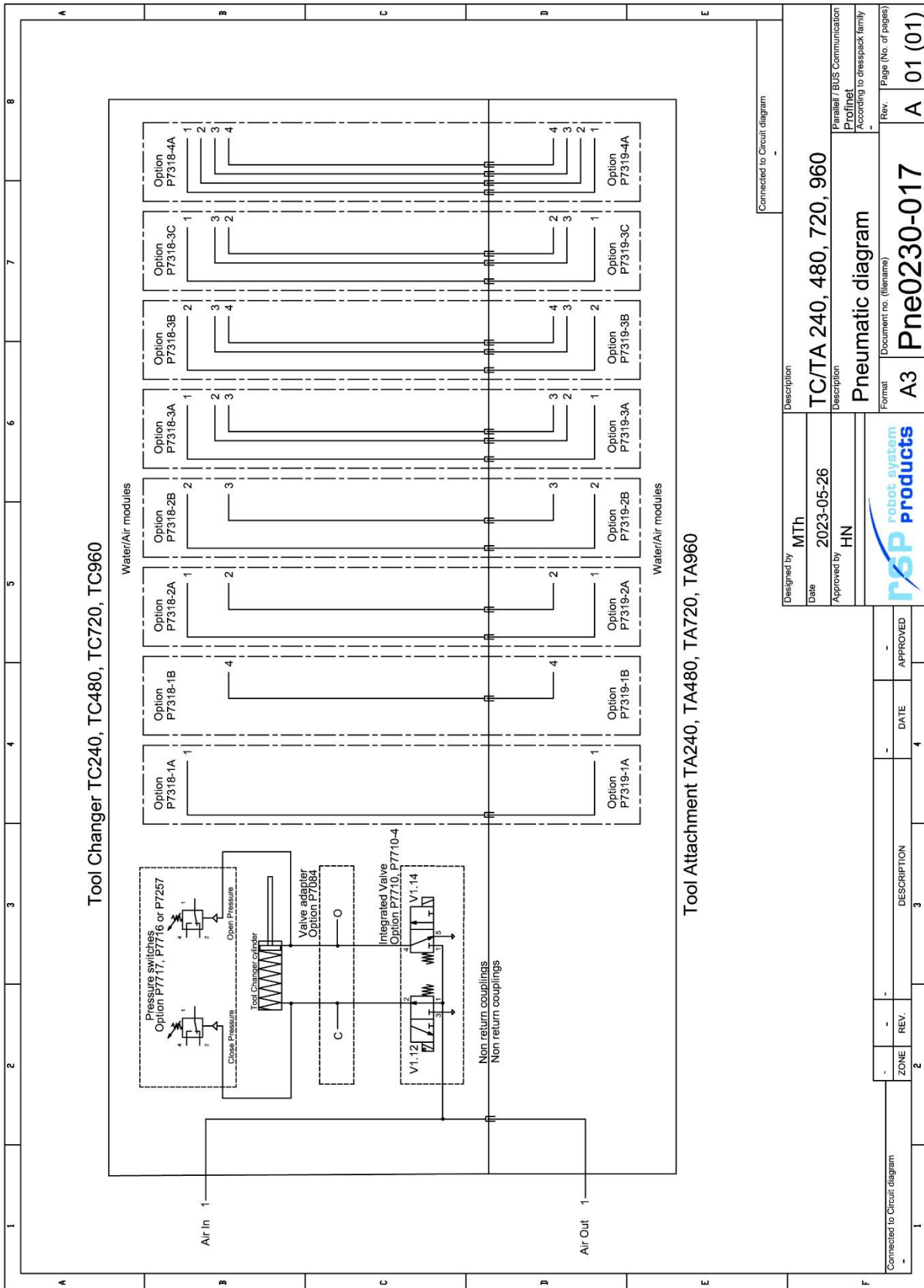

We reserve rights in this document and the information contained therein. Reproduction, use or disclosure to third parties without express authority is strictly forbidden. Robot System Products

8.1.2 Configuration of couplings, A0230-627

1	2	3	4	5	6	7	8
ZONE		REV.	DESCRIPTION		DATE	CHANGED	APPROVED
<p>P7318-1A</p> <p>P7318-1B</p> <p>P7318-2A</p> <p>P7318-2B</p> <p>P7318-3A</p> <p>P7318-3B</p> <p>P7318-3C</p> <p>P7318-4A</p>							
<p>P7318-1A</p> <p>Number of couplings</p> <p>Positioning/numbering configuration</p> <p>Mating product P7319-xx</p>							
<p>Unless otherwise stated the following applies:</p> <p>Tolerance: <input type="checkbox"/> <input checked="" type="checkbox"/></p> <p>Surface roughness: <input type="checkbox"/> <input checked="" type="checkbox"/></p> <p>Burring class acc. to: <input type="checkbox"/> <input checked="" type="checkbox"/></p> <p>Measures valid after treatment / cooling</p> <p>Designed by: HN 2023-05-23 Scale: 1:2</p> <p>Approved by: MATH Weight: 1.16</p> <p>rsp robot system products</p> <p>Material: Heat treatment / Surface coating</p> <p>Circuit diagram: A0230-627</p> <p>Description: TC Water/air module, model 2023</p> <p>To Moduflex TC</p> <p>Item no.: P7318 Rev.: A</p> <p>Sheet: 1(2)</p>							

We reserve rights in this document and in the information contained therein. Reproduction, use or disclosure to third parties without express authority is strictly prohibited. Robot System Products

8.2 Water/air coupling, 1–4 channels, tool side. Article: P7319

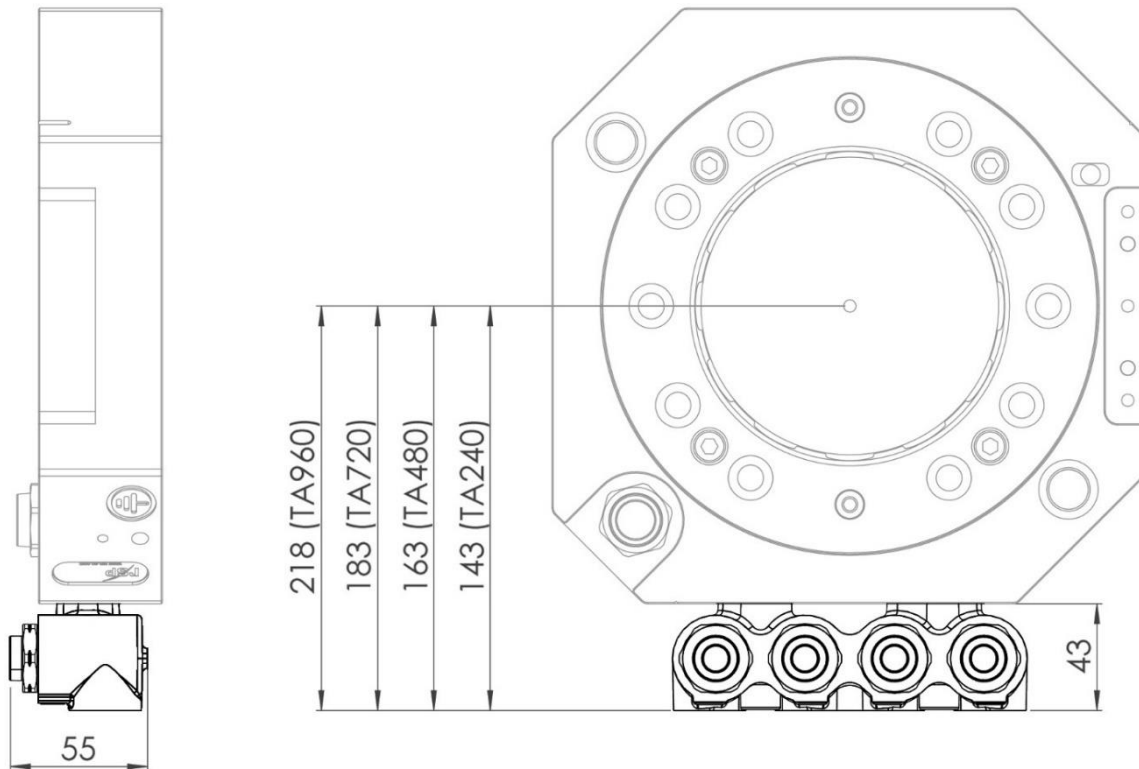

Transfers 1–4 water/air-channels, with non-return valves, to the tool. To be mounted at the tool attachment and used together with option P7318 attached to the tool changer.

Technical data

Weight	1.4–1.6 kg (depending on no. of ducts)	
Water/air channels	Total number of ducts	1–4 (see article numbers. below)
	Water/air quality	Max 25µm particle content

Number of ducts		Article numbers
Water/air channels	1	P7319-1A/1B
	2	P7319-2A/2B/2C/2D
	3	P7319-3A/3B/3C
	4	P7319-4A
Configuration of water/air couplings		A0230-628 (section 8.2.1)

8.2.1 Configuration of couplings, A0230-628

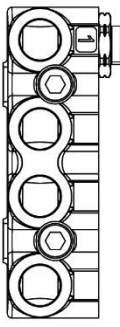
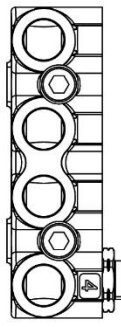
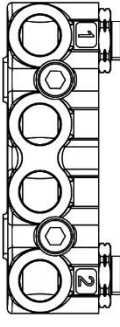
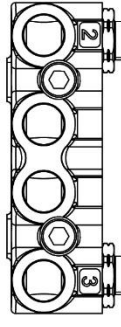
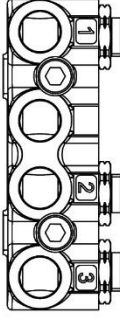
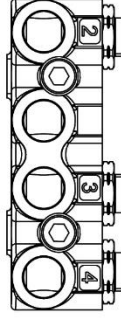
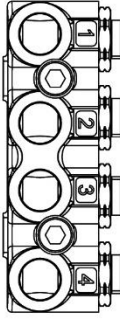
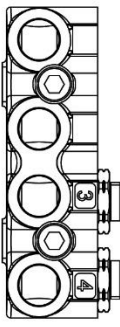
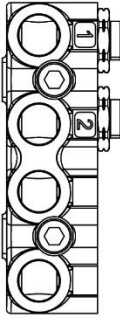
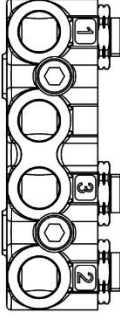
1	2	3	4	5	6	7	8
ZONE		REV.	DESCRIPTION		DATE	CHANGED	APPROVED
							
	P7319-1A	P7319-1B	P7319-2A	P7319-2B	P7319-3A	P7319-3B	P7319-4A
							
			P7319-2C	P7319-2D	P7319-3C		
<p>P7319-1A</p> <p>Number of couplings</p> <p>Positioning/numbering configuration</p> <p>Mating product P7318-xx</p>							
<p>Unless otherwise stated the following applies:</p> <p>Tolerance: <input type="checkbox"/></p> <p>Surface roughness: <input checked="" type="checkbox"/></p> <p>Burring class acc. to: <input type="checkbox"/></p> <p>Measures valid after treatment / cooling</p>				<p>Material</p> <p>Heat treatment / Surface cooling</p> <p>Circuit diagram</p> <p>Filename</p>			
<p>Designed by</p> <p>HN</p> <p>Approved by</p> <p>MATH</p>				<p>Scale</p> <p>1:2</p> <p>Weight</p> <p>1.17</p>			
<p>2023-05-23</p>				<p>Description</p> <p>TA Water/air module, model 2023</p> <p>To Modulflex TA</p>			
<p>rsp robot system products</p>				<p>Item no.</p> <p>P7319</p>			
<p>Format</p> <p>A3</p>				<p>Rev.</p> <p>A</p>			
<p>Sheet</p> <p>1(2)</p>							

We reserve rights in this document and in the information contained therein. Reproduction use or disclosure to third parties without express authority is strictly prohibited. Robot System Products

8.3 Air coupling, 8 channels, robot side. Article: P6847

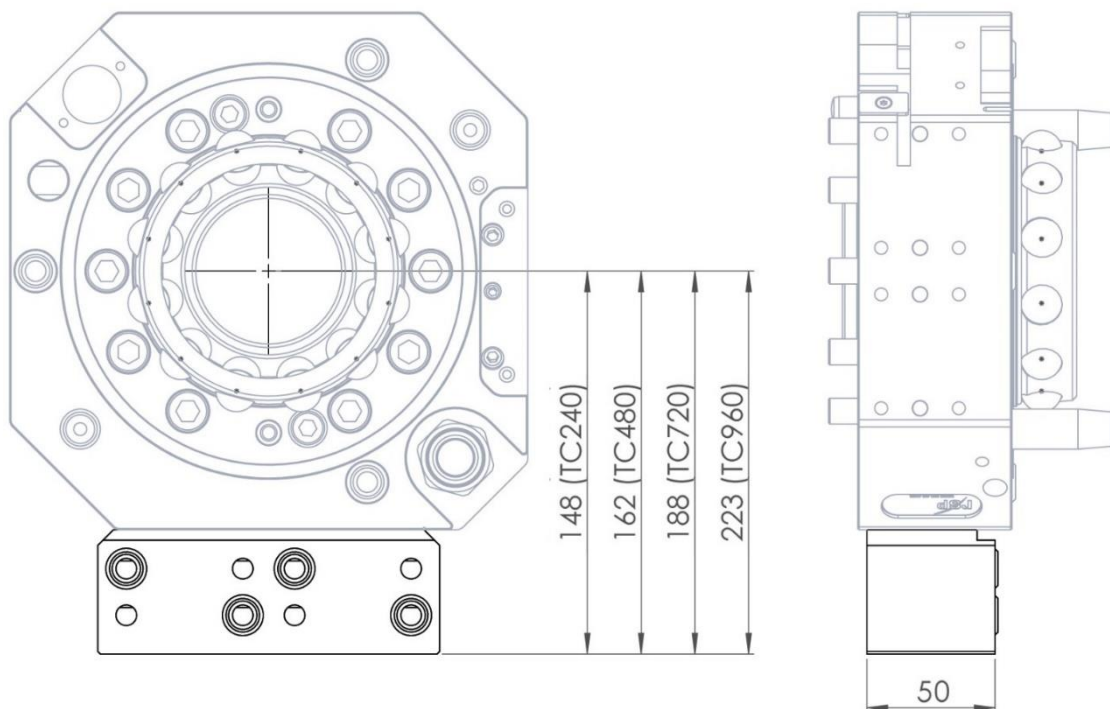

Transfers 8 pneumatic channels to the tool attachment. Can be mounted at 2 different positions on the tool changer. To be used together with option P6848 attached to the tool attachment.

Technical data

Weight		0.8 kg
Air channels	Total number of ducts	8 x G 1/4" (1000 l/min, max 10 bar)
	Air quality	Oil-clean and waterless filtered air, with max 25µm particle content

8.4 Air coupling, 8 channels, tool side. Article: P6848

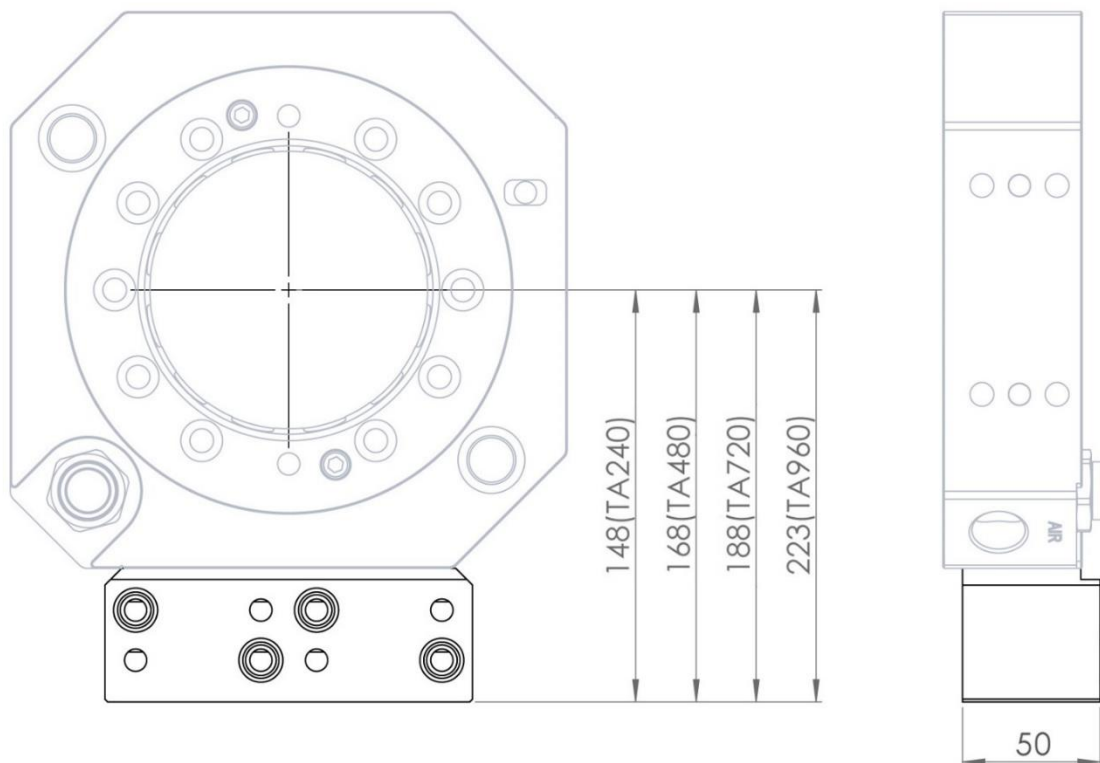

Transfers 8 pneumatic channels to the tool. To be mounted at the tool attachment and used together with option P6847 attached to the tool changer.

Technical data

Weight		0.8 kg
Air channels	Total number of ducts	8 x G 1/4"
	Air quality	Oil-clean and waterless filtered air, with max 25µm particle content

9 WELD POWER MODULES

9.1 Weld power connector M40, robot side. Article: P6716

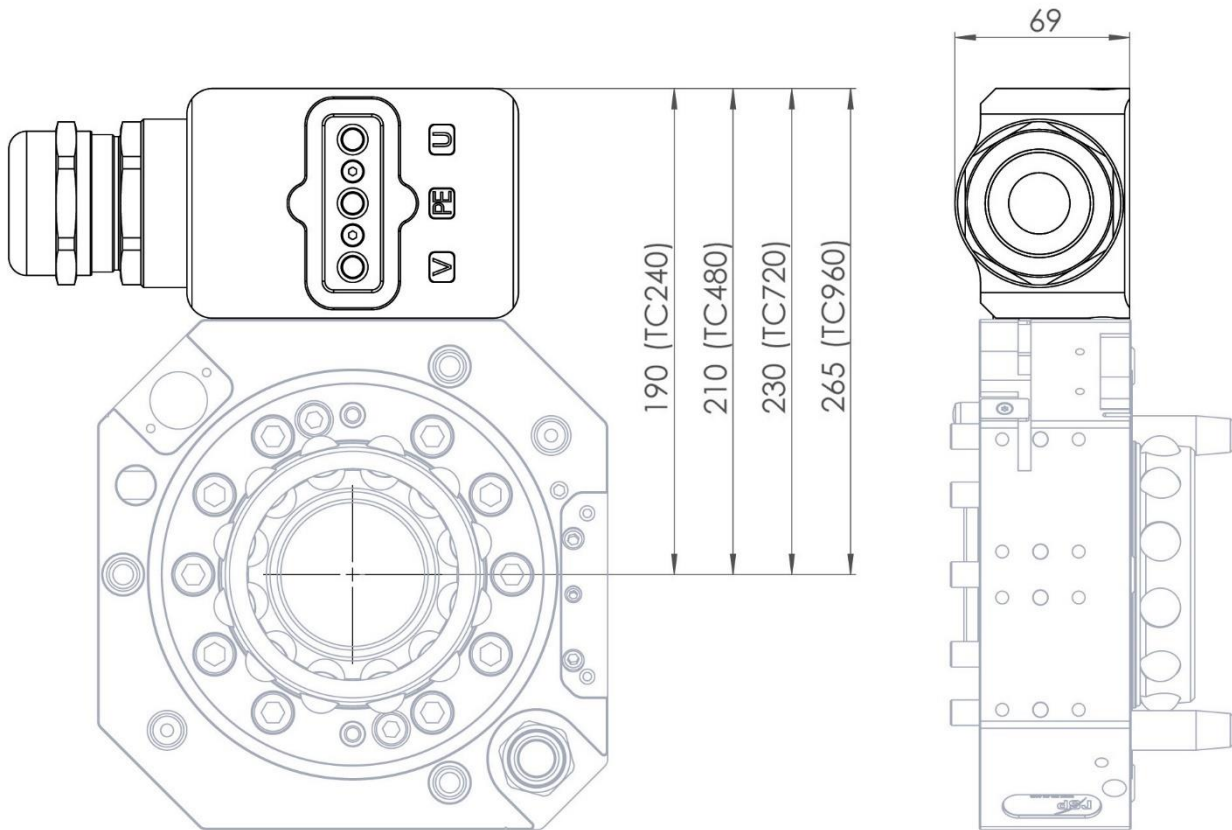

Connects 3 weld power conductors to the tool attachment. Can be mounted at two different positions at the tool changer and with the cable gland to the left or the right. To be used together with option P6726 attached to the tool attachment.

Technical data

Weight		1.1 kg
Weld power	Total number of conductors	3 x (690V, 140A)
	Connection	Cable gland (M40x1.5) for a 3-conductor 19–28 mm cable

9.2 Weld power connector M50, robot side. Article: P6784

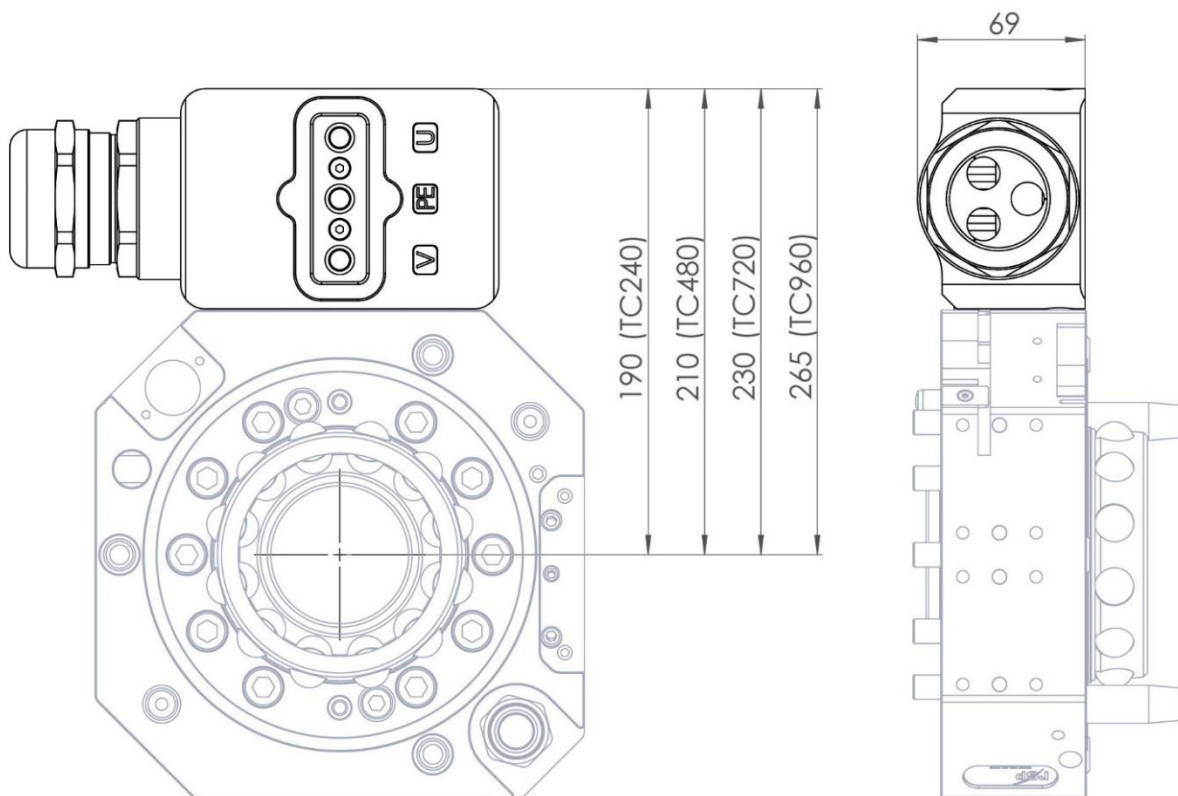

Connects 3 weld power conductors to the tool attachment Can be mounted at two different positions at the tool changer and with the cable to the left or the right. To be used together with option P6726 attached to the tool attachment.

Technical data

Weight		1.2 kg
Weld power	Total number of conductors	3 x (690V, 140A)
	Connection	Cable gland (M50 with insert grommet) for three 15 mm separate cables

9.3 Weld power connector, MC connector, robot side. Article: P6717

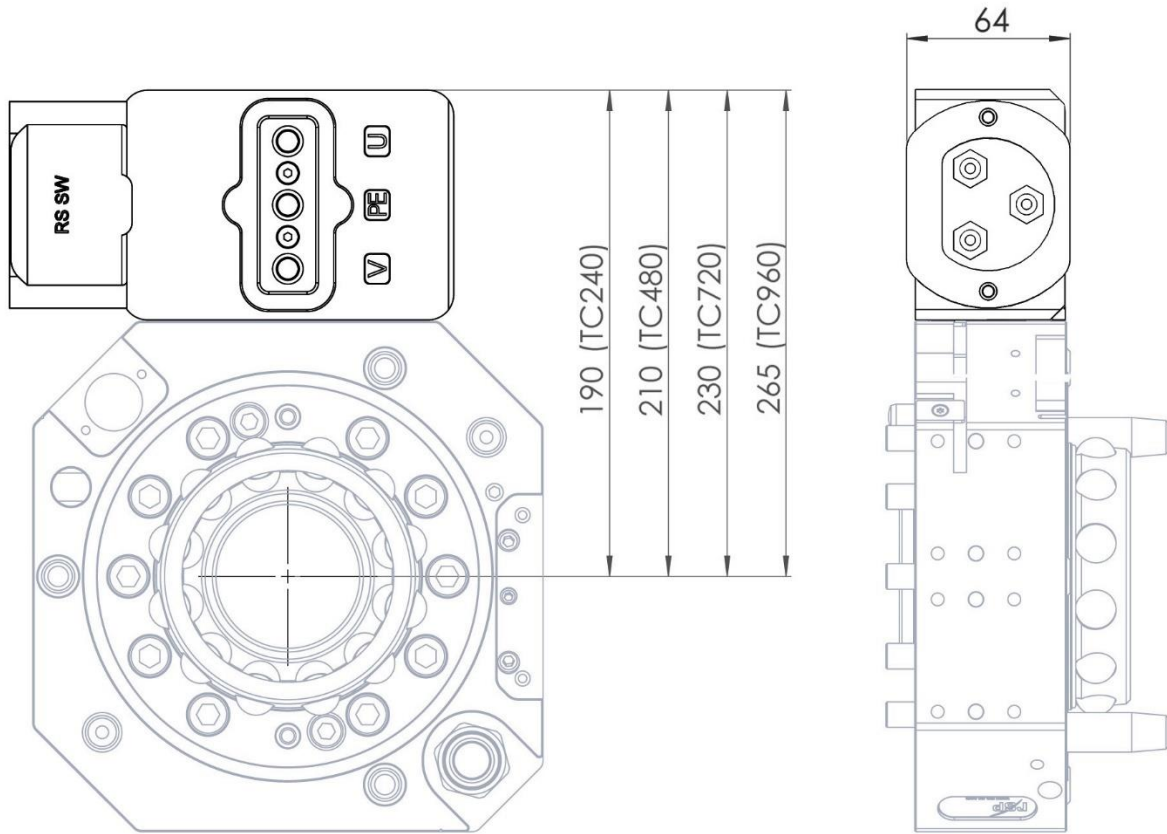

Connects 3 weld power conductors to the tool attachment. Can be mounted at two different positions at the tool changer and with the MC connector to the left or the right. To be used together with option P6726 attached to the tool attachment.

Technical data

Weight		1.1 kg
Weld power	Total number of conductors	3 x (690V, 140A)
	Connection	Corresponds to MC TSB150

9.4 Weld power connector with RobiFix, robot side. Article: P6794

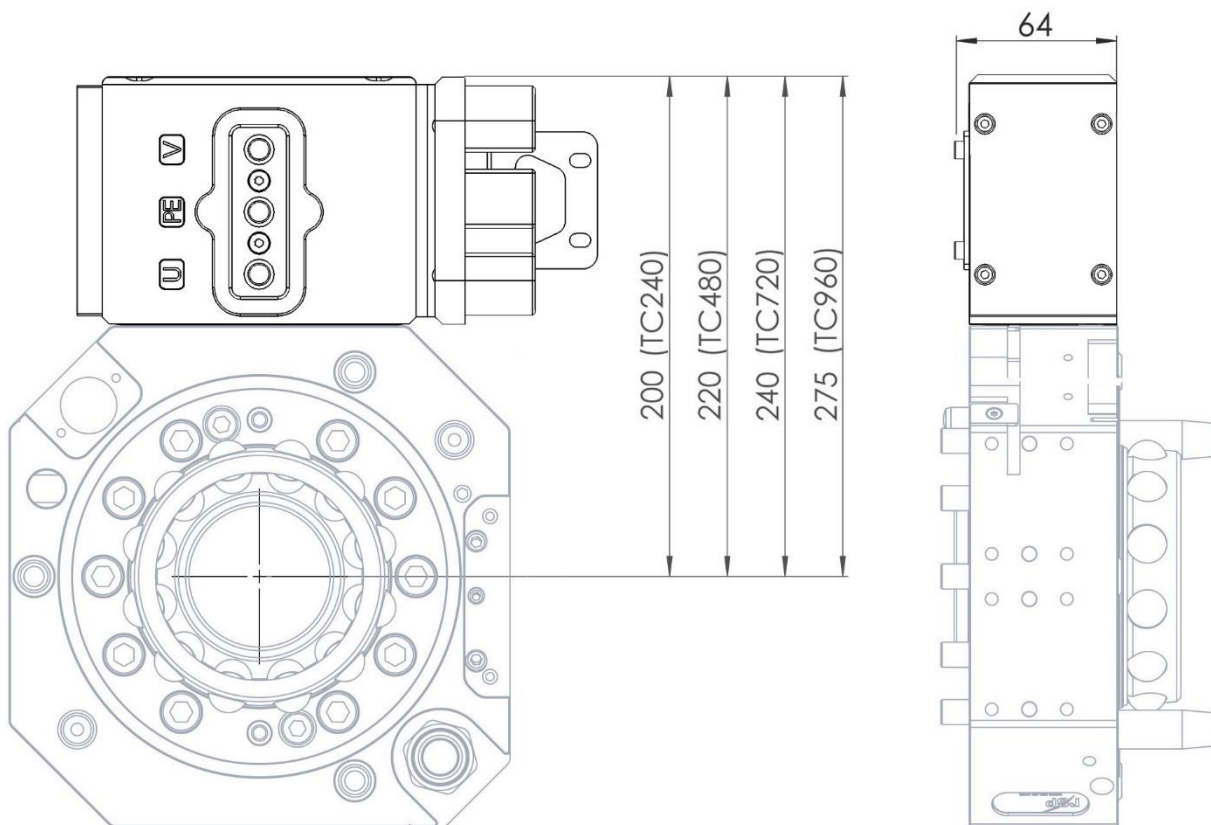

Connects 3 weld power conductors to the tool attachment. Can be mounted at one position at the tool changer with the RobiFix connector to the right. To be used together with option P6726 attached to the tool attachment.

Technical data

Weight		1.1 kg
Weld power	Total number of conductors	3 x (690V, 140A)
	Connection	Corresponds to Robifix S35

9.5 Weld power connector with cable gland, tool side. Article: P6726

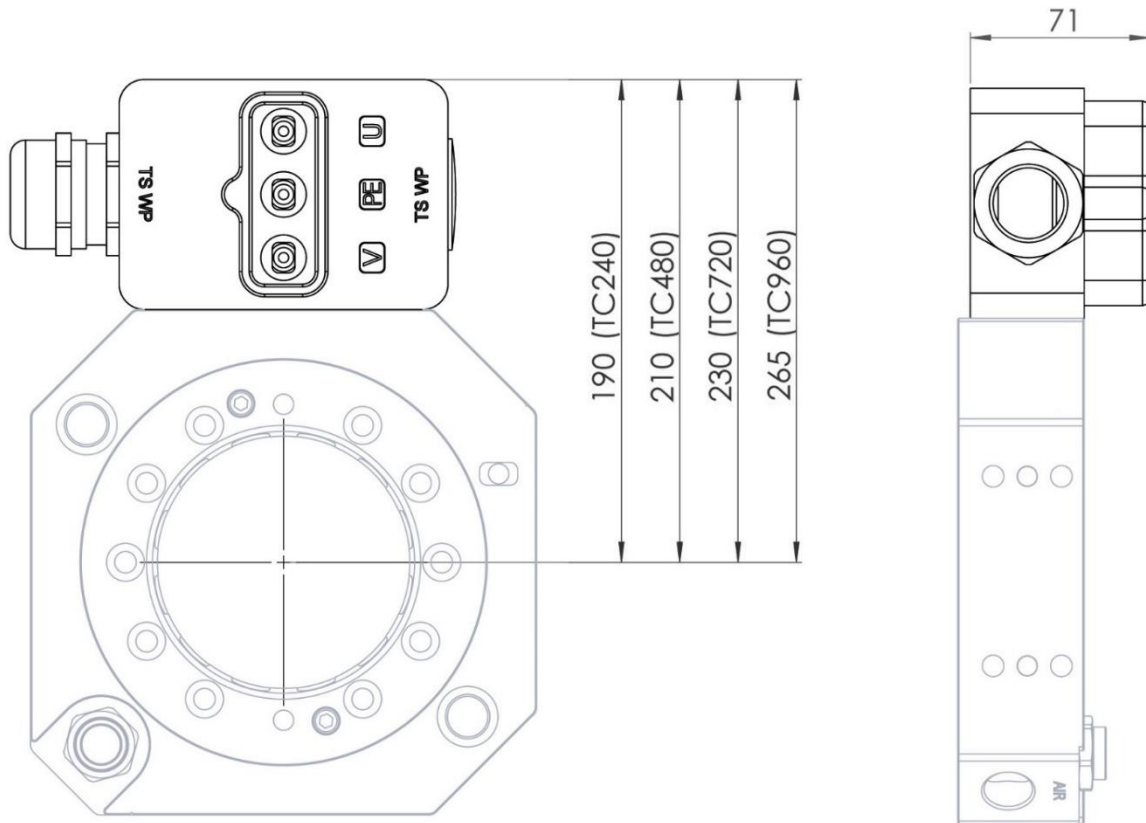

Connects 3 weld power conductors to the tool. Can be mounted at the tool attachment with cable gland to the left or the right. To be used together with option P6716, P6784 or P6794 attached to the tool changer.

Technical data

Weight		1.1 kg
Weld power	Total number of conductors	3
	Connection	Cable gland for a 3-conductor 19–28 mm cable
Connection kits (optional)	P1521 (cable)	Power cable 1.5 m (3x25mm) with cable lugs

9.6 Weld power connector with 3 cables, tool side. Article: P1517

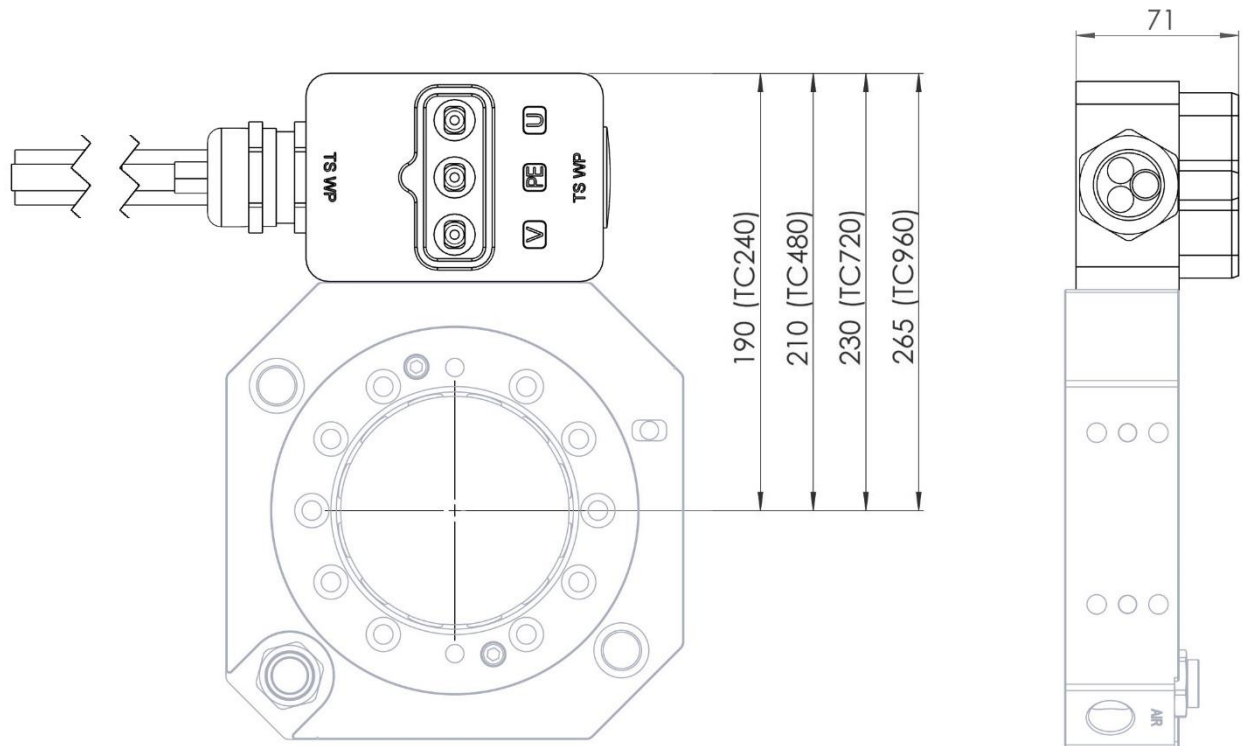

Connects 3 weld power conductors to the tool. To be mounted at the tool attachment and used together with option P6784 attached to the tool changer.

Technical data

Weight		1.2–1.4 kg
Weld power	Total number of conductors	3
	Connection	Cable gland for 3 x 11 mm cables
	Cable (included)	3 x 1.4m (single wire) cables, 25 mm ²

9.7 Weld power connector 2 x M40, robot side. Article: P6766

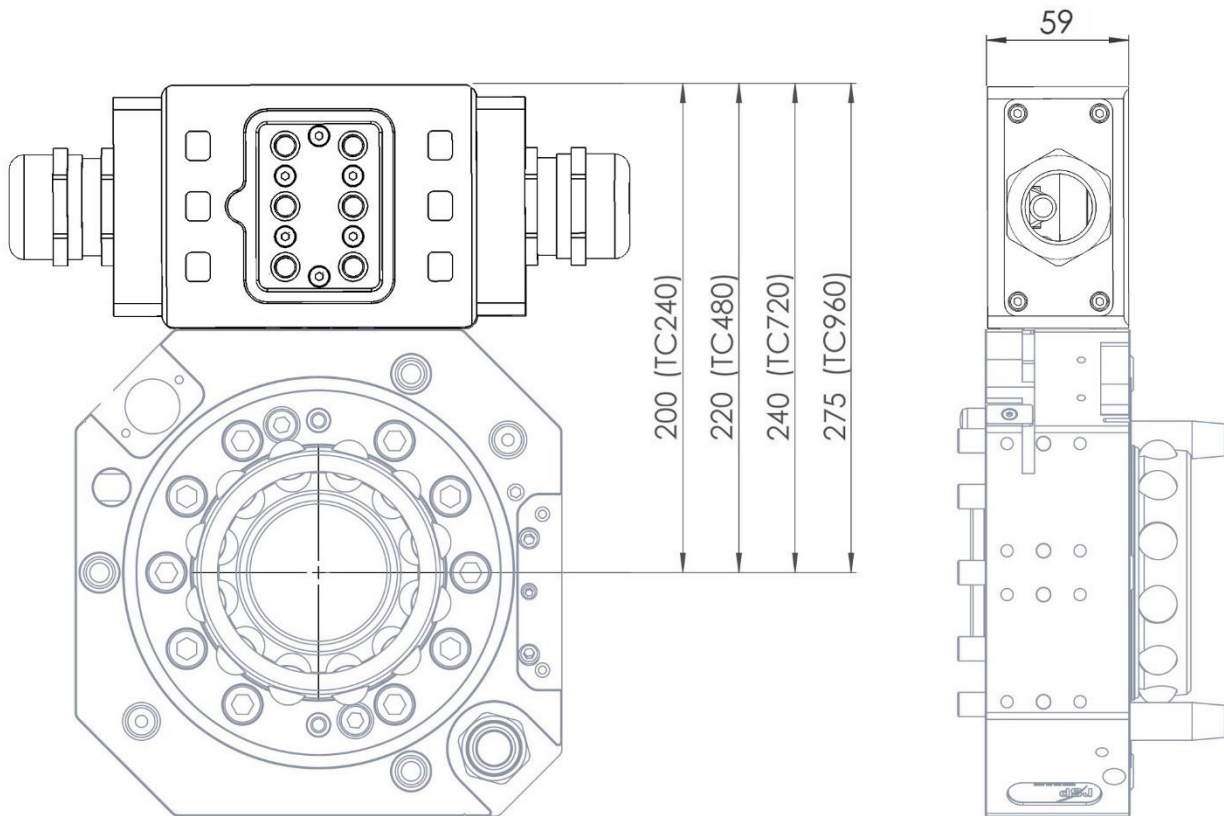

Connects 6 weld power conductors to the tool attachment Can be mounted at two different positions at the tool changer. To be used together with option P6767 attached to the tool attachment.

Technical data

Weight		1.5 kg
Weld power	Total number of conductors	2 x 3 x (690V, 140A)
	Connection	2 x Cable glands (M40x1.5) for 3-conductor 19–28 mm cables

9.8 Weld power connector with 2 x cable gland, tool side.
Article: P6767

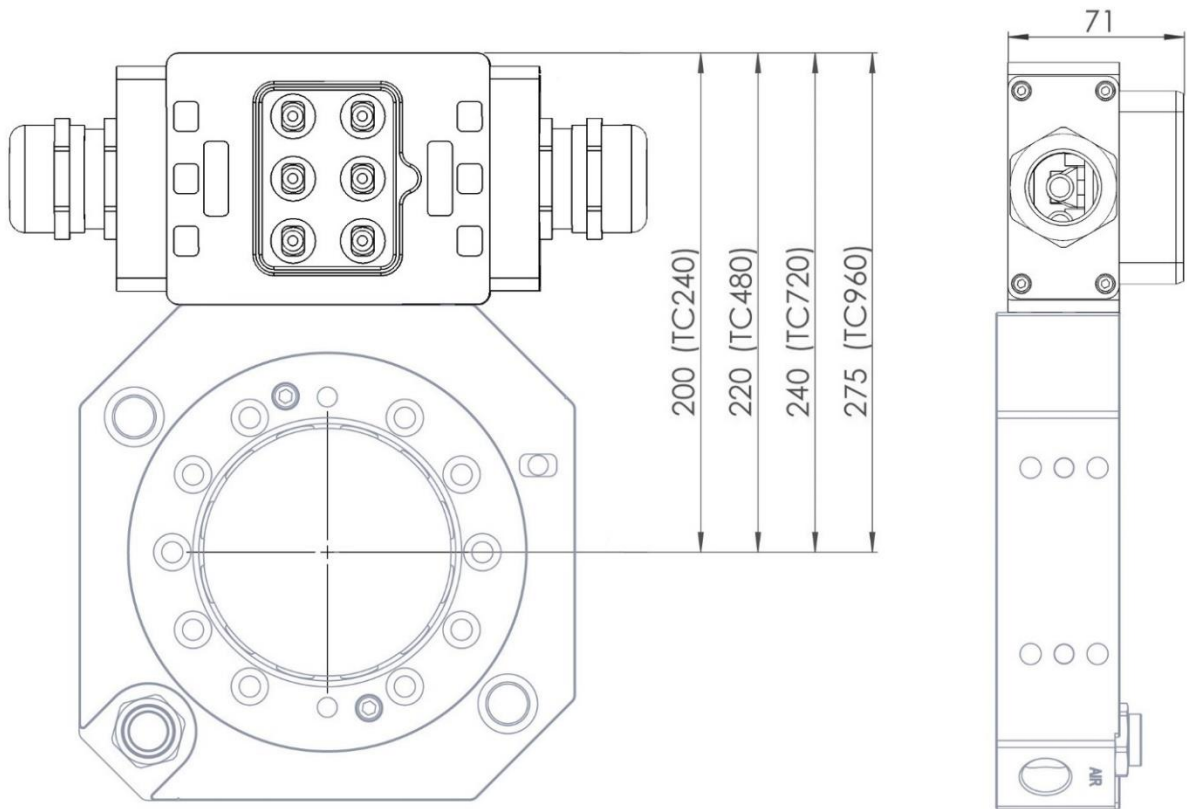

Connects 2 x 3 weld power conductors to the tool. To be mounted at the tool attachment and used together with option P6766 attached to the tool changer.

Technical data

Weight		1.4 kg
Weld power	Total number of conductors Connection	2 x 3 2 x Cable glands for 3-conductor 19–28 mm cable
Connection kits (optional)	P1521 (cable)	Power cable 1.5 m (3x25mm) with cable lugs

9.9 Weld power connector with 2 x RobiFix, robot side. Article: P7336

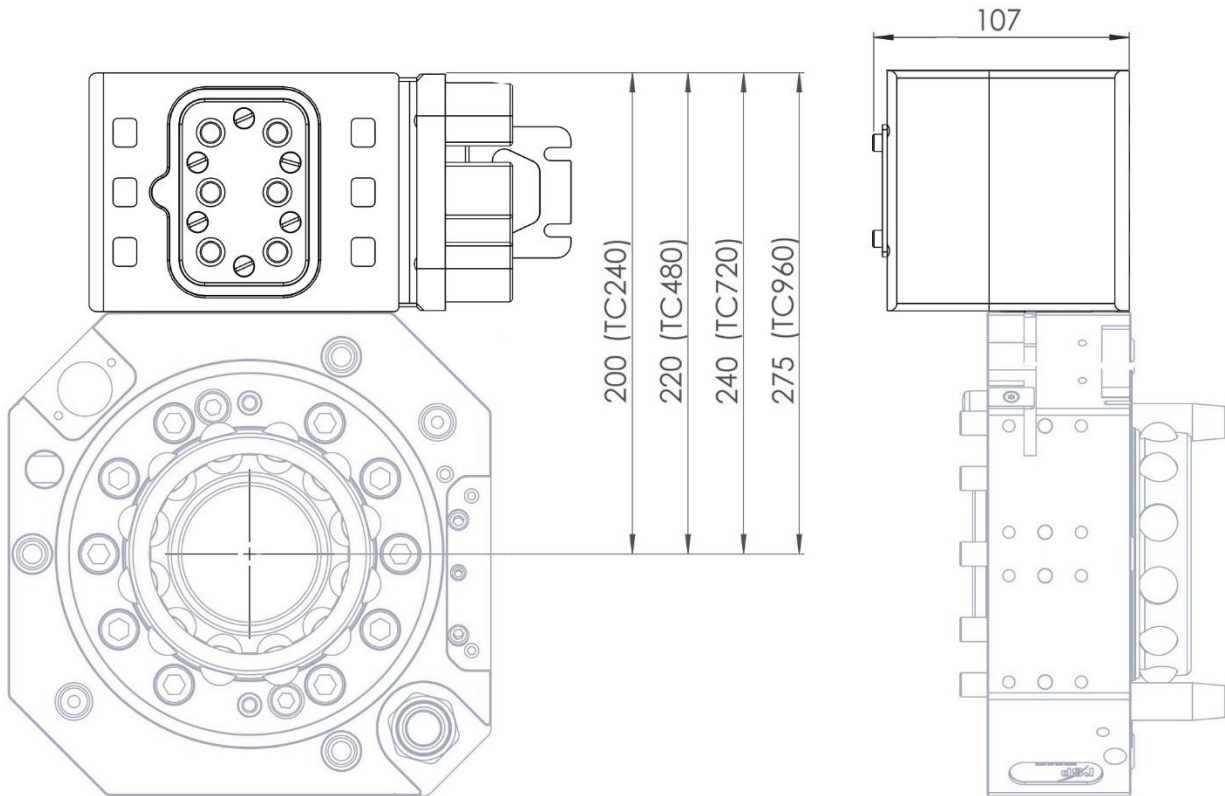

Connects 6 weld power conductors to the tool attachment. Can be mounted at two different positions at the tool changer with the RobiFix connectors to the right. To be used together with option P7337 attached to the tool attachment.

Technical data

Weight		2.6 kg
Weld power	Total number of conductors	2 x 3 x (690V, 140A)
	Connections	Corresponds to Robifix S35



NOTE! To avoid collisions between robot and connector a spacer plate between the robot flange and the tool changer might be required. Please contact RSP!

9.10 Weld power connector 6 x cable gland, tool side. Article: P7337

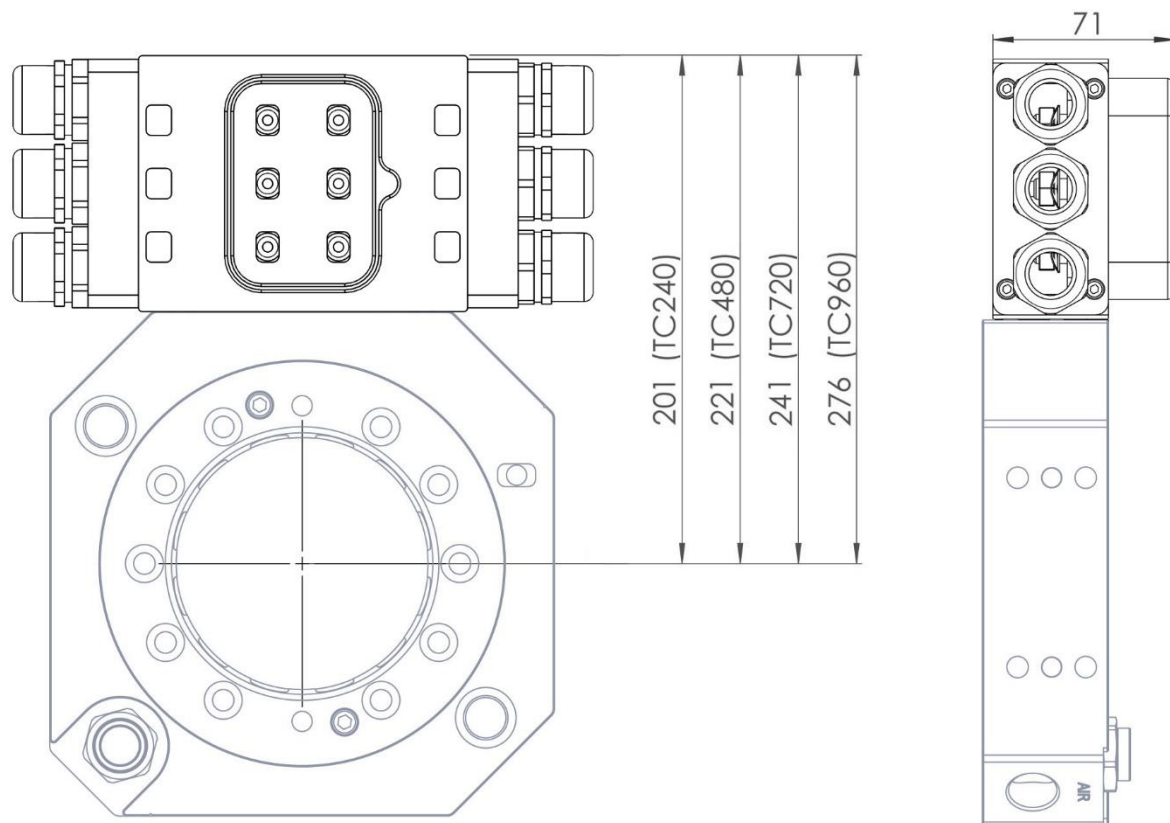

Connects 6 weld power conductors to the tool To be mounted at the tool attachment and used together with option P7336 attached to the tool changer.

Technical data

Weight		1.4 kg
Weld power	Total number of conductors	2 x 3
	Connection	6 x Cable glands (M25x1,5) for 9-17 mm cables

9.11 Weld power connector cover, tool side. Article: P6742

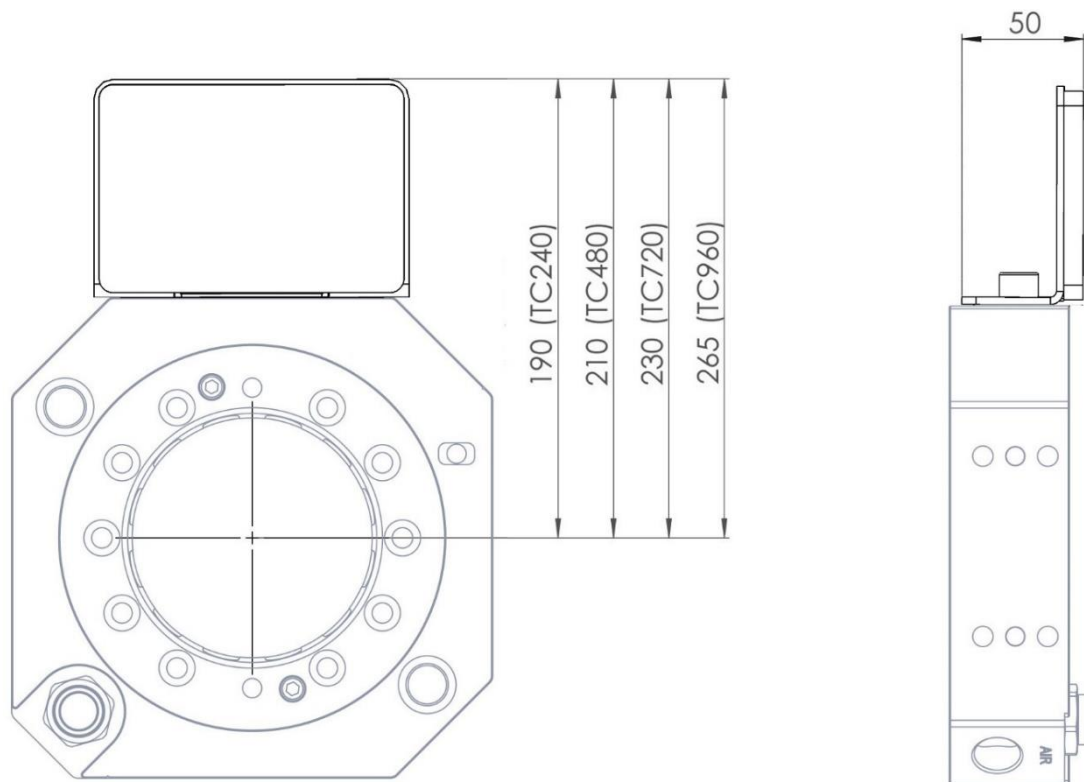

To be used together with options P6716, P6717, P6794, P6766 and P7336 when no power connector are used on tool attachment.

Technical data

Weight	0.2 kg
---------------	--------

10 SAFETY SIGNAL MODULES. ARTICLE: P7501-XXX

The RSP Safety signal modules, P7501-XXX, combine transfer of control signals and power with an built-in safety unit. It is designed both for material handling (MH) and spot-welding with servo gun (SWS) and is available for a number of robot brands and connections (examples in section 10.1–10.10). Using the Safety signal module, the tool changer will not open – independent of control signal from the robot controller – unless it is empty or, alternatively, when the tool changer with tool attachment and tool is safely docked in a tool stand. The Safety signal module is designated with: P7501-XXX, where XXX is dependent on different variants of signal interfaces.

Technical data and dimensions, robot side

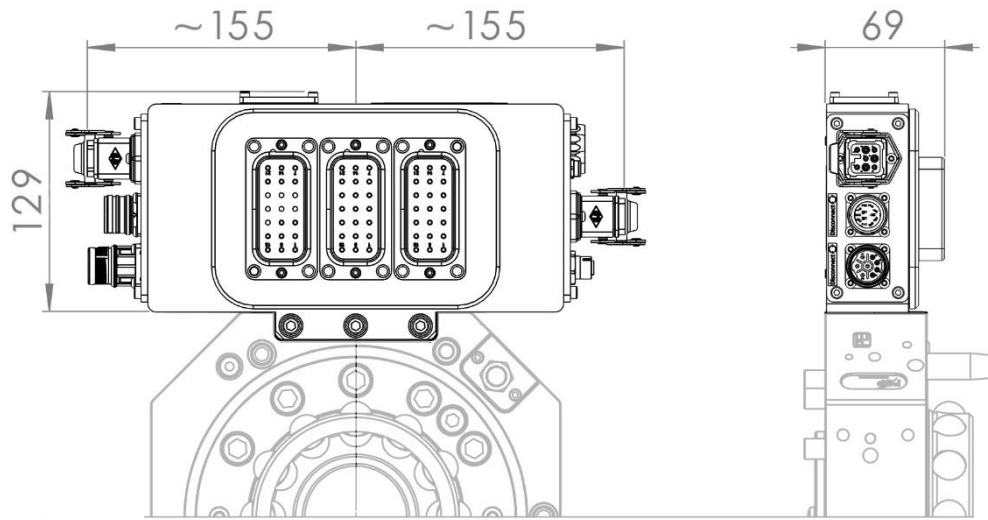

Weight	2.6 kg
Product manual	M8353-1

Technical data and dimensions, tool side

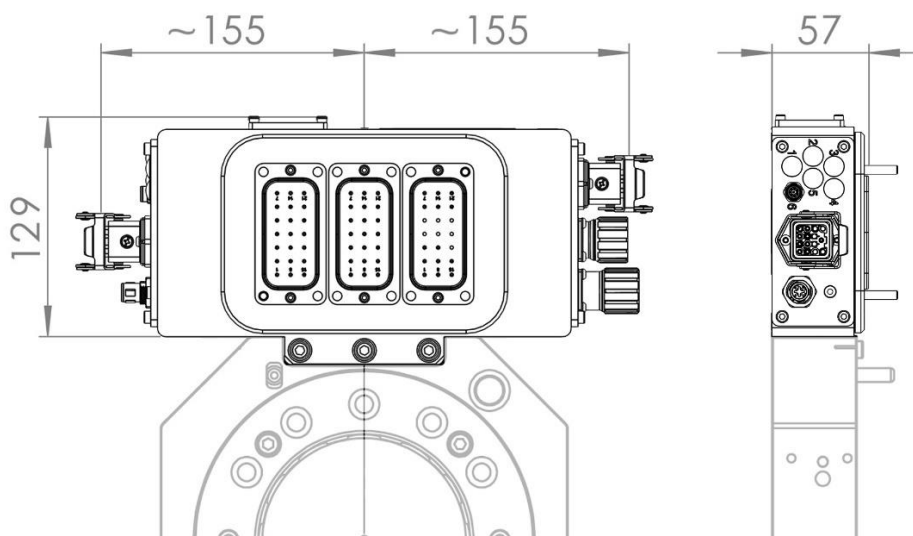

Weight	2.3 kg
Product manual	M8353-1

10.1 Safety module, MH, robot side (ABB compatible): P7501-075

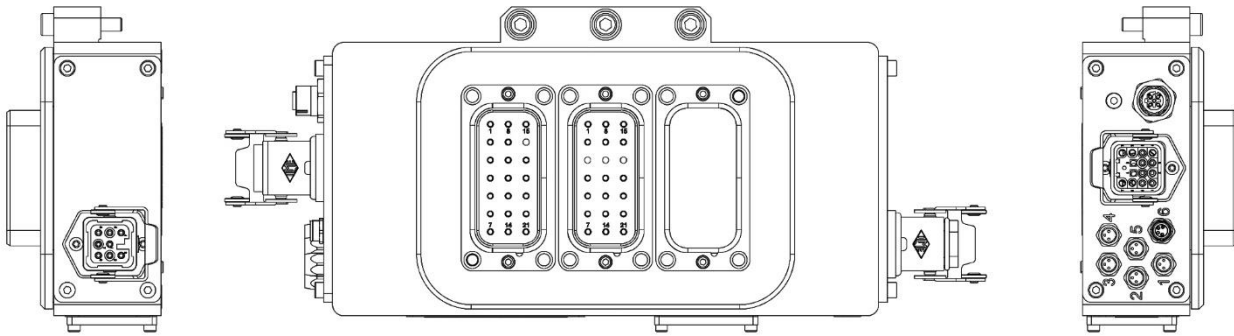

Technical data

Circuit diagram	E0203-578 (separately available)	
Connections	M12 D-Coded, Female (Phoenix 1437766)	Profinet
	12p, Male (Ilme CKAXS 03, CQM 12)	2 x (24V, 0V) + PE
	8p, Male (Ilme CKAXS 03, CDM 08)	KSR + 6 x signals
	5 x M8 3S (Lumberg RKMF 3-0,5 M)	TC_Empty, TC_Opened, TC_Closed, TC_Open_Pressure, TC_Close_Pressure
	M8 4S (Phoenix 1456093)	Open_TC1, Open_TC2

10.2 Safety module, MH, tool side (ABB compatible): P7501-074

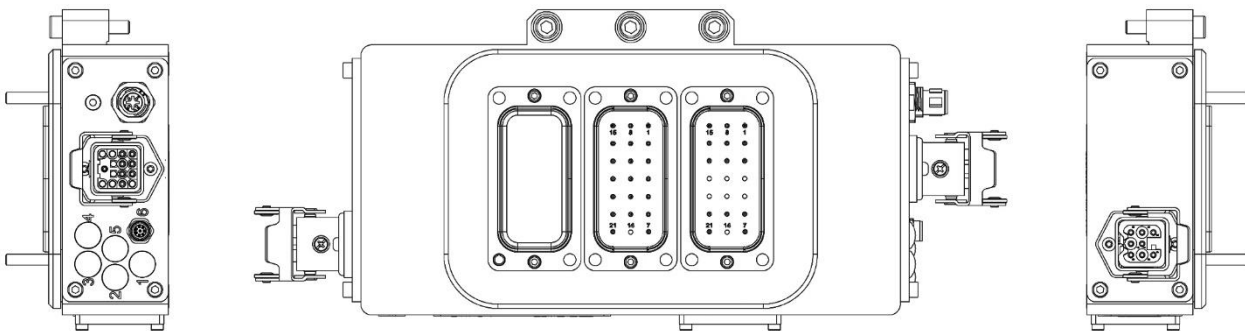

Technical data

Circuit diagram	E0203-573 (separately available)	
Connections	M12 4P D-Coded, Male (Phoenix 1437805)	Profinet
	M8 8S A-Coded, (Phoenix 1424231)	Tool in stand signals
	12p, Female (Ilme CKAXS 03, CQF 12)	2 x (24V, 0V) + PE
	8p, Female (Ilme CKAXS 03, CQF 08)	KSR + 6 x signals

10.3 Safety module, SWS, robot side (ABB compatible): P7501-072

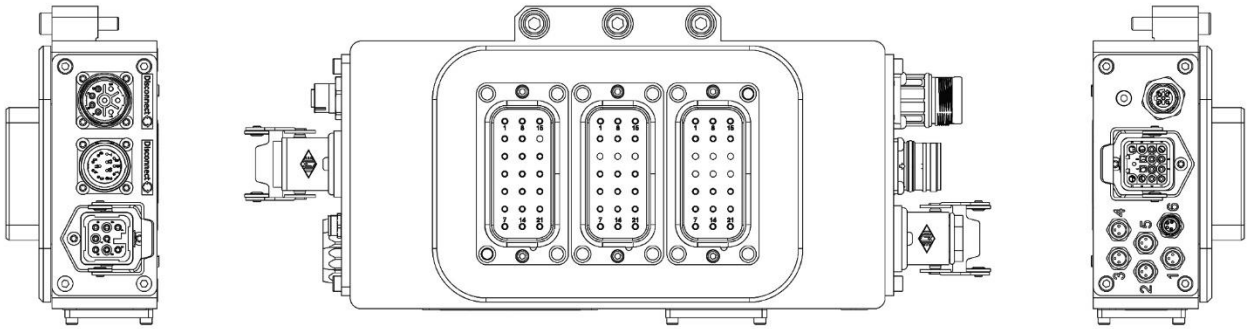

Technical data

Circuit diagram		E0203-576 (separately available)
Connections	M12 D-Coded, Female (Phoenix 1437766)	Profinet
	12p, Male (Ilme CKAXS 03, CQM 12)	2 x (24V, 0V) + PE
	8p, Male (Ilme CKAXS 03, CDM 08)	KSR + 6 x signals
	M23 12P, Male (Hummel 7410 000 000, 7003 912 101)	Resolver signals
	M23 8P, Male (Hummel 7601 000 000, 7084 943 101)	Servo power, brake release, PTC
	5 x M8 3S (Lumberg RKM 3-0,5 M)	TC_Empty, TC_Opened, TC_Closed, TC_Open_Pressure, TC_Close_Pressure
	M8 4S (Phoenix 1456093)	Open_TC1, Open_TC2

10.4 Safety module, SWS, tool side (ABB compatible): P7501-073

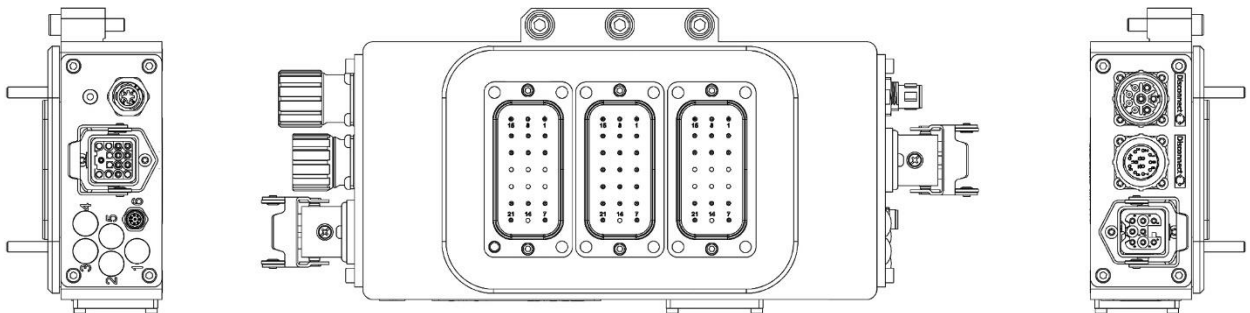

Technical data

Circuit diagram		E0203-572 (separately available)
Connections	M12 4P D-Coded, Male (Phoenix 1437805)	Profinet
	M8 8S A-Coded, (Phoenix 1424231)	Tool in stand signals
	12p, Female (Ilme CKAXS 03, CQF 12)	2 x (24V, 0V) + PE
	8p, Female (Ilme CKAXS 03, CQF 08)	KSR + 6 x signals
	M23 12S, Female (Hummel 7440 00 00, 7003 912 102)	Resolver signals
	M23 8S, Female (Hummel 7641 000 000, 7084 943 102)	Servo power, brake release, PTC

10.5 Safety module, MH, robot side (KUKA compatible): P7501-076

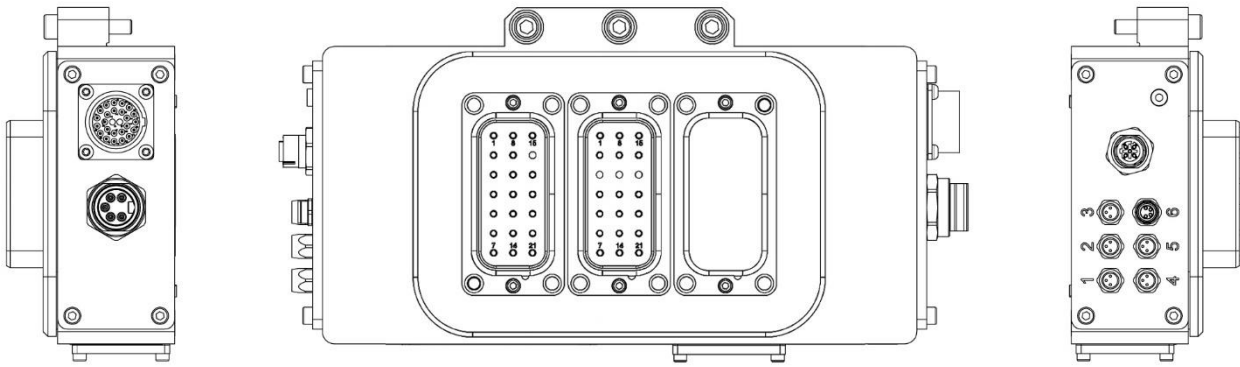

Technical data

Circuit diagram	E0203-242 (separately available)	
Connections	M12 D-Coded, Female (Phoenix 1437766)	Profinet
	7/8" (Harting 21 34 740 0571 005)	2 x (24V, 0V) + PE
Connections	Souriau compact 26P, Male, UT0W01626PH	23 signals + PE
	5 x M8 3S (Lumberg RKMF 3-0,5 M)	TC_Empty, TC_Opened, TC_Closed, TC_Open_Pressure, TC_Close_Pressure
	M8 4S (Phoenix 1456093)	Open TC1, Open TC2

10.6 Safety module, MH, tool side (KUKA compatible): P7501-077

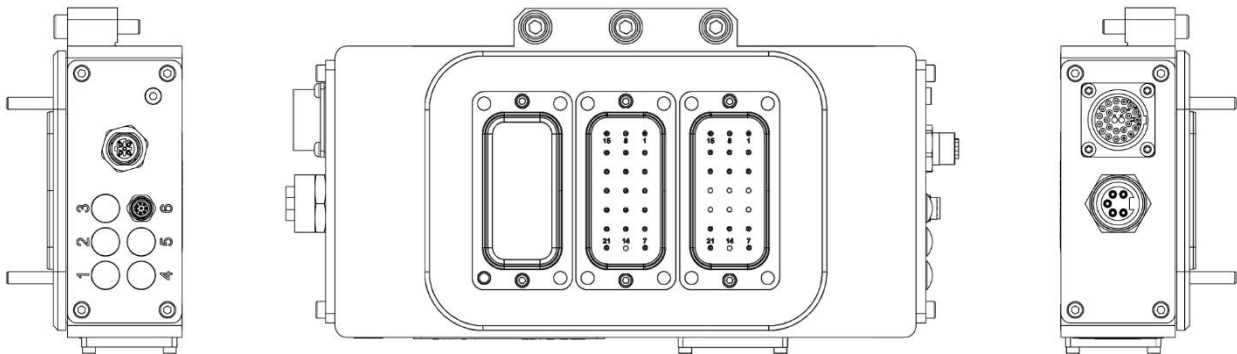

Technical data

Circuit diagram	E0203-243 (separately available)	
Connections	M12 D-Coded, Female (Phoenix 1437766)	Profinet
	M8 8S, Female (Phoenix 1437766)	Tool in stand signals
	7/8" 5S, Female (Phoenix 1521449)	2 x (24V, 0V) + PE
Connections	Souriau compact 26S, Female, UT0W01626SH	23 signals + PE

10.7 Safety module, SWS, robot side (KUKA compatible): P7501-078

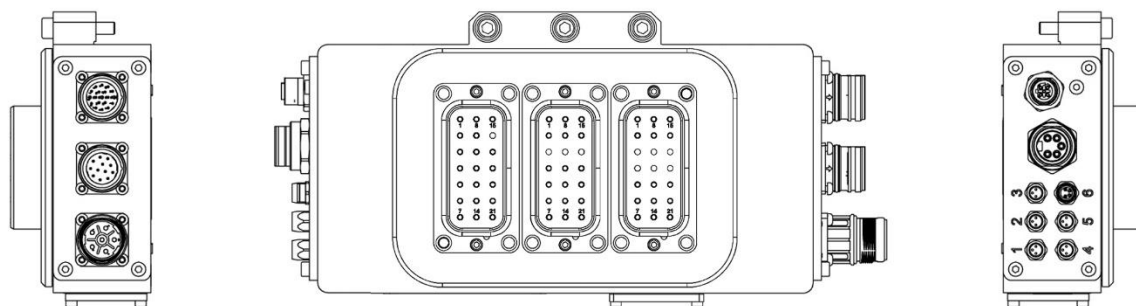

Technical data

Circuit diagram	E0203-319 (separately available)
Connections	M12 D-Coded, Female (Phoenix 1437766)
	7/8" 5P, Male (Murr 700-78241-9780050)
	M23 19P, Male (Hummel 7410 000 000, 7003 919 101)
	M23 12P, Male (Hummel 7410 000 000, 7004 912 101)
	M23 6P, Male (Hummel 7601 000 000, 7084 951 101)
	5 x M8 3S (Lumberg RKMF 3-0,5 M)
	M8 4S (Phoenix 1456093)
	Profinet
	2 x (24V, 0V) + PE
	Weld power signals
	Resolver signals
	Servo power, brake release + PE
	TC_Empty, TC_Opened, TC_Closed, TC_Open_Pressure, TC_Close_Pressure
	Open_TC1, Open_TC2

10.8 Safety module, SWS, tool side (KUKA compatible): P7501-079

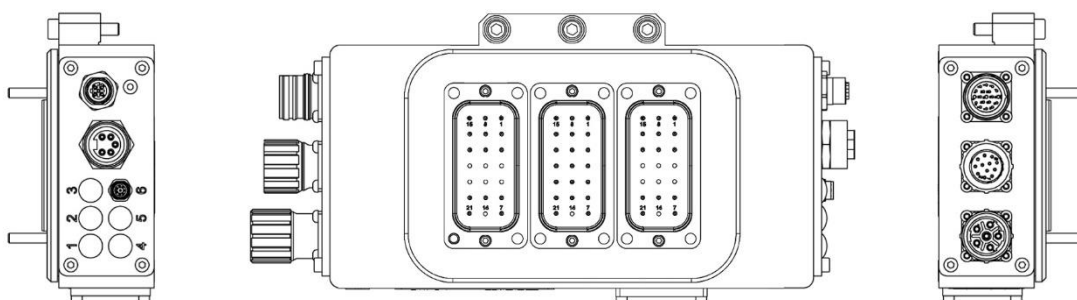

Technical data

Circuit diagram	E0203-325 (separately available)
Connections	M12 D-Coded, Female, Phoenix 1437766
	M8 8S, Female, (Phoenix 1424231)
	7/8" 5S, Female (Phoenix 1521449)
	M23 19S, Female (Hummel 7410 000 000, 7003 919 102)
	M23 12S Female (Hummel 7440 000 000, 7004 912 102)
	M23 6S (Hummel 7641 000 000, 7084 951 102)
	Profinet
	Tool in stand signals
	2 x (24V, 0V) + PE
	Weld power signals
	Resolver signals
	Servo power, brake release + PE

10.9 Safety module, MH, robot side (Yaskawa compatible): P7501-823

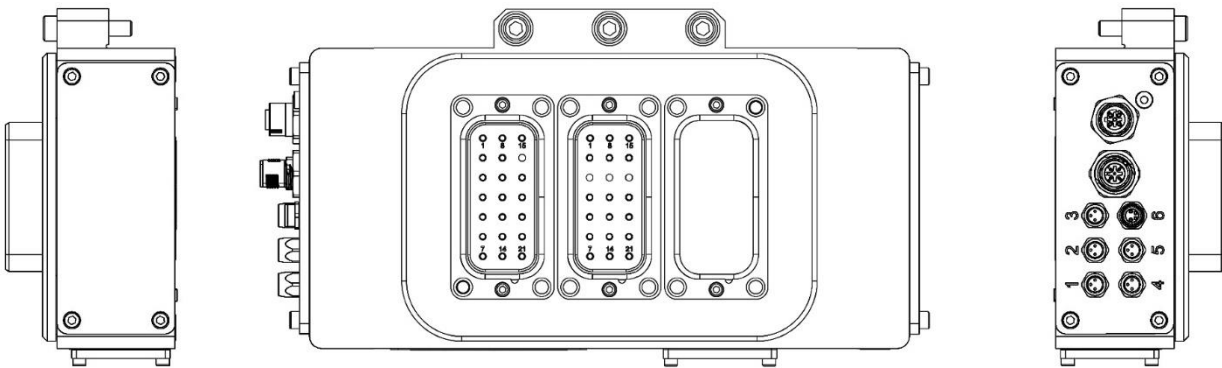

Technical data

Circuit diagram	E0203-410 (separately available)	
Connections	M12 D-Coded, Female (Phoenix 1437766)	Profinet
	M12 5P, A-Coded, Male (Phoenix 1419645)	2 x (24V, 0V) + PE
	5 x M8 3S (Lumberg RKMF 3-0,5 M)	TC_Empty, TC_Opened, TC_Closed, TC_Open_Pressure, TC_Close_Pressure
	M8 4S (Phoenix 1456093)	Open_TC1, Open_TC2

10.10 Safety module, MH, tool side (Yaskawa compatible): P7501-824

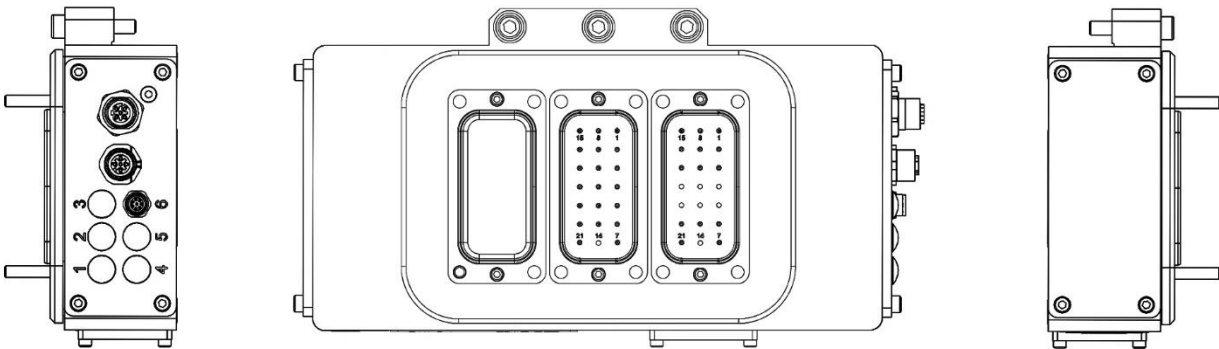

Technical data

Circuit diagram	E0203-411 (separately available)	
Connections	M12 D-Coded, Female (Phoenix 1437766)	Profinet
	M8 8S, Female (Phoenix 1424229)	Tool in stand signals
	M12 5S A-coded, Female (Phoenix 1520042)	2 x (24V, 0V) + PE

11 OTHER MODULES

11.1 Programming tool for TC480. Articles: P7160 and P7162



To be used on TC-side for programming of docking TA480 to TC480. P7160 is, together with P7161 on the TA side, used for TC480 Type A with 3 guide pins and P7162 is, together with P7163 on the TA side, used for TC480 Type B with 2 guide pins.

Technical data

Weight	2.6 kg
--------	--------

11.2 Programming tool for TA480. Articles: P7161 and P7163



To be used on TA-side for programming of docking TA480 to TC480. P7161 is used together with P7160 on the TC side and . P7163 is used together with P7162 on the TC side.

Technical data

Weight	1.8 kg
--------	--------

11.3 TC ground socket. Article: P7239

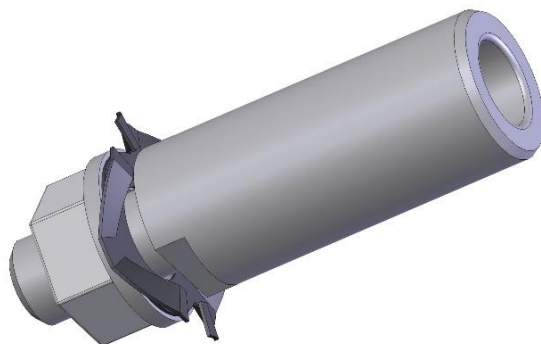

To be mounted at the tool changers TC720-1 (P6901A) or TC960-1 (P7901A and P7901A-1) and used for ground connection between the tool changer, tool attachment and robot.

Technical data

Weight	0.01 kg
Connection, ground	M5/M8 (screw holes on tool changer)
Max current	140A

11.4 TA ground socket. Article: P7147

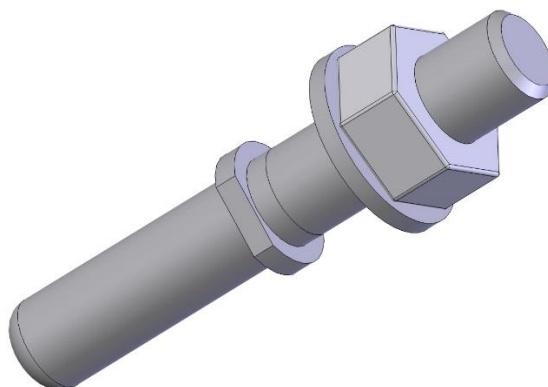

To be mounted at the tool attachments TA720-1 (P6902A) or TA960-1 (P7902A) and used for ground connection between tool attachment, tool changer and tool.

Technical data

Weight	0.01 kg
Connection, ground	M5/M8 (screw holes on tool attachment)
Max current	140A

11.5 Pressure booster kit. Article: P8213-1

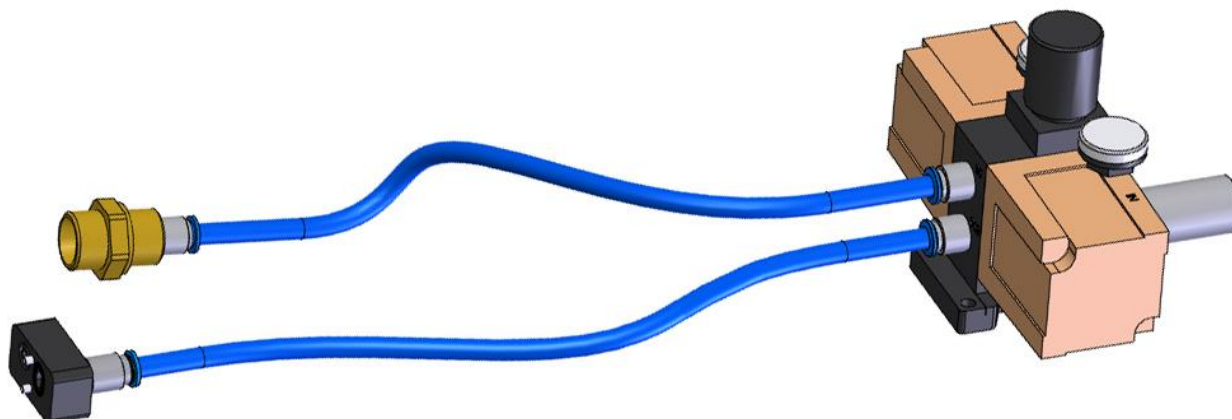

Pressure booster kit P8213-1 should be used for manual unlocking by connecting pneumatic air. Increases air pressure two times without any need of power supply, To be mounted to the Open TC (marked O) on the tool changers TC240-1, TC480-1, TC720-1 or TC960-1.

Technical data

Weight	0.6 kg
Connection robot side	G 1/2" (max 10 bar)
Connection TC-side	Valve adaptor for Open TC (marked O)
Length of hoses	0.55 m

11.6 Forced opening kit. Article: P6910



Forced opening kit P6910 should be used for manual unlocking by connecting a grease gun, To be mounted to dedicated connections at the tool changers TC240-1, TC480-1, TC720-1 or TC960-1.

Technical data

Weight	0.2 kg
--------	--------



NOTE! Primarily to be used, in the extremely rare occasions, when opening by the Pressure booster kit P8213-1 has failed.

11.7 Robot adaptation kits

The flange of the tool changers has fastening holes in accordance with ISO 9409. For other bolt circles adaptation plates, to be mounted between the tool changer and the robot flange, are available. The product numbers of the adaptation kits are depending on actual combination of robot and tool changer.

11.8 Limitation of Robot movements

There can be some limitations on the movement of axis 5 for some robot models. Contact Robot System Products for more information.

11.9 Tool Identification

Jumpers on signals at the tool attachment can be used to give information about which tool attachment that is docked in the tool changer.

12 SPARE PARTS

12.1 Tool changer side

12.1.1 Parts list for integrated valve, P6718

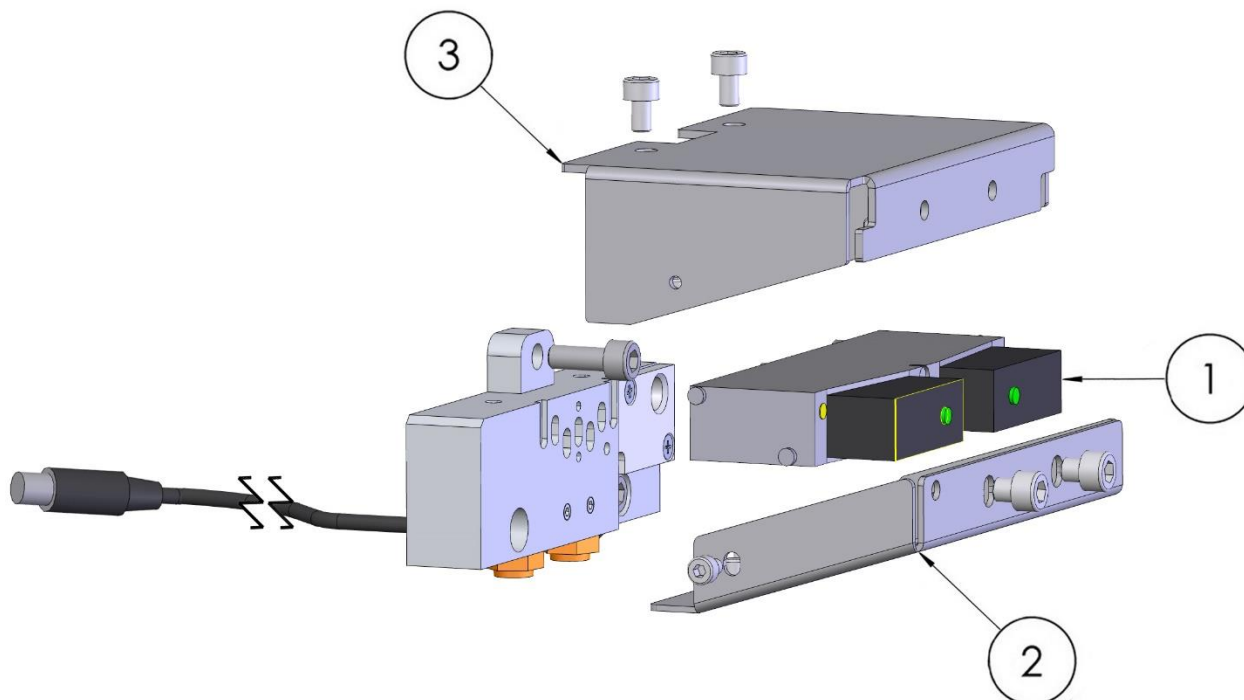

Item	Description	Part number	Wear part	Pcs
1	Valve	I0449		1
2	Valve cover hose protection	P0178-223		1
3	Valve cover	P0178-138		1

12.1.2 Parts list for integrated valve, P7710 and P7710-4

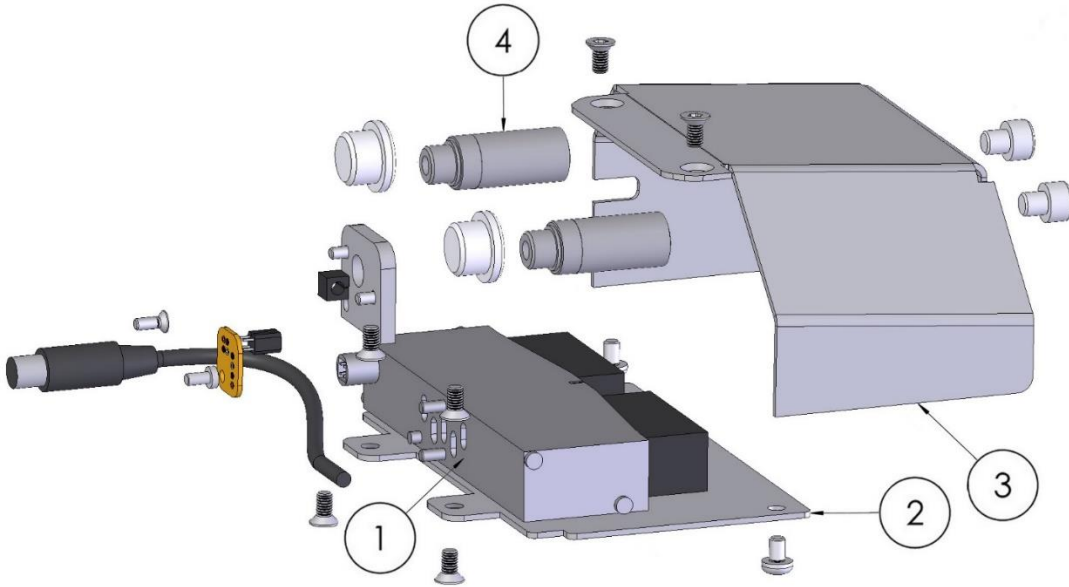

Item	Description	Part number	Wear part	Pcs
1	Valve	I0449		1
2	Rear valve cover	P0178-324		1
3	Valve cover	P0178-323		1
4	Silencer	I0903		2

12.1.3 Parts list for valve adapter, P7084

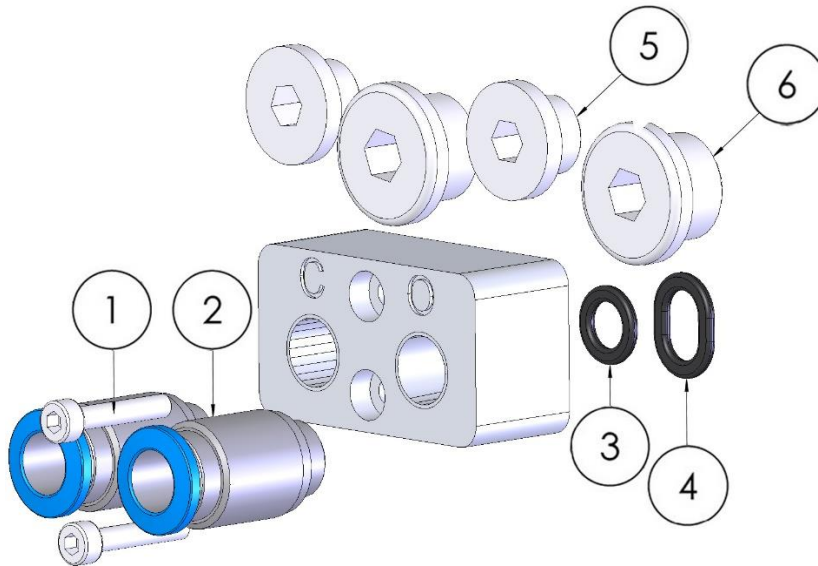

Item	Description	Part number	Wear part	Pcs
1	Mounting screw, M3x16	21212519-228		2
2	Air connection	I0371		2
3	O-ring	I0090		1
4	O-ring	I0436		1
5	Blind plug	I0093		2
6	Blind plug	I0165		2

12.1.4 Parts list for magnetic sensors, P6789, P6873-2

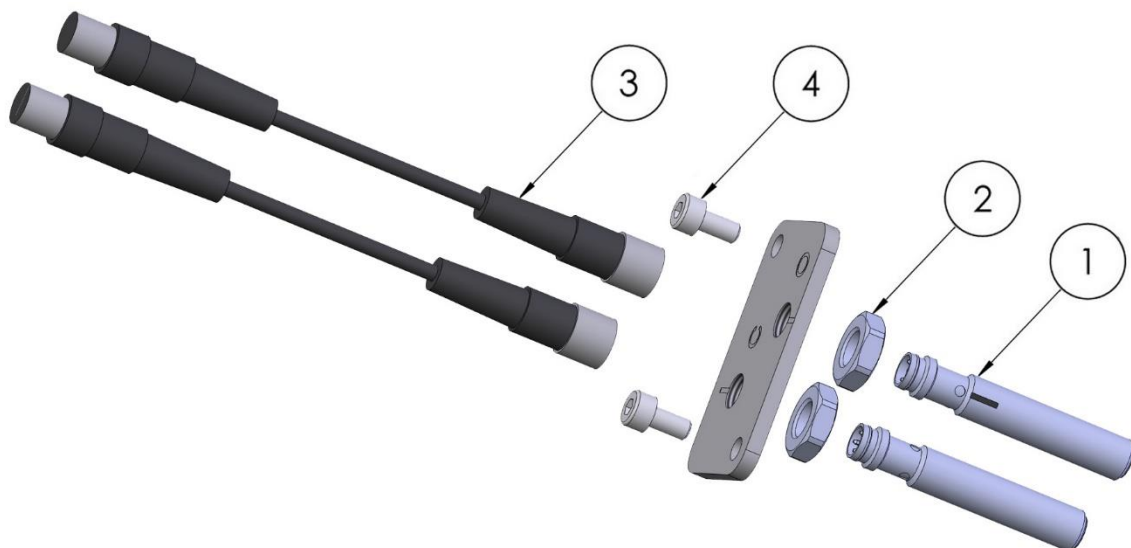

Item	Description	Part number	Wear part	Pcs
1	Magnetic sensor	I1015		2
2	Nut	101469		2
3	Sensor cable M8	I1288		2
4	M4x8 screw	MC6S M4x8		2

12.1.5 Parts list for magnetic sensors P7172, P7173, P7174, P7293 and P7175

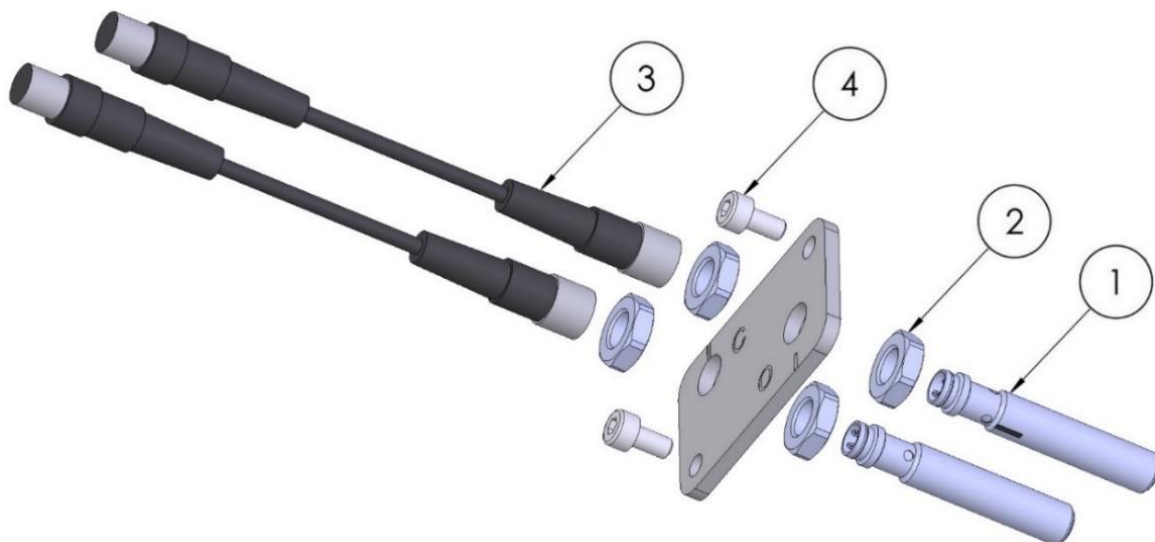

Item	Description	Part number	Wear part	Pcs
1	Magnetic sensor	I1015		2
2	Nut	101469		4
3	Sensor cable M8	I1288		2
4	M4x8 screw	MC6S M4x8		2
4	M4x8 screw (P7175 only)	MC6S M4x8		4

12.1.6 Parts list for tool in stand sensor, active. P8528

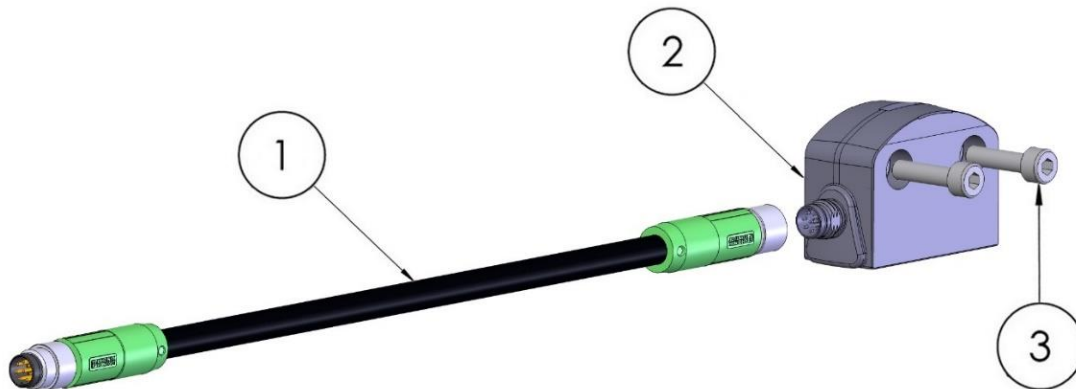

Item	Description	Part number	Wear part	Pcs
1	Cable, M8 8P-M8 8S	I1260		1
2	Position switch, active	I1171		1
3	Screw, M4x16	21212519-293		2

12.1.7 Parts list for signal interface, P6738-1, P7224, P6711 and P6771

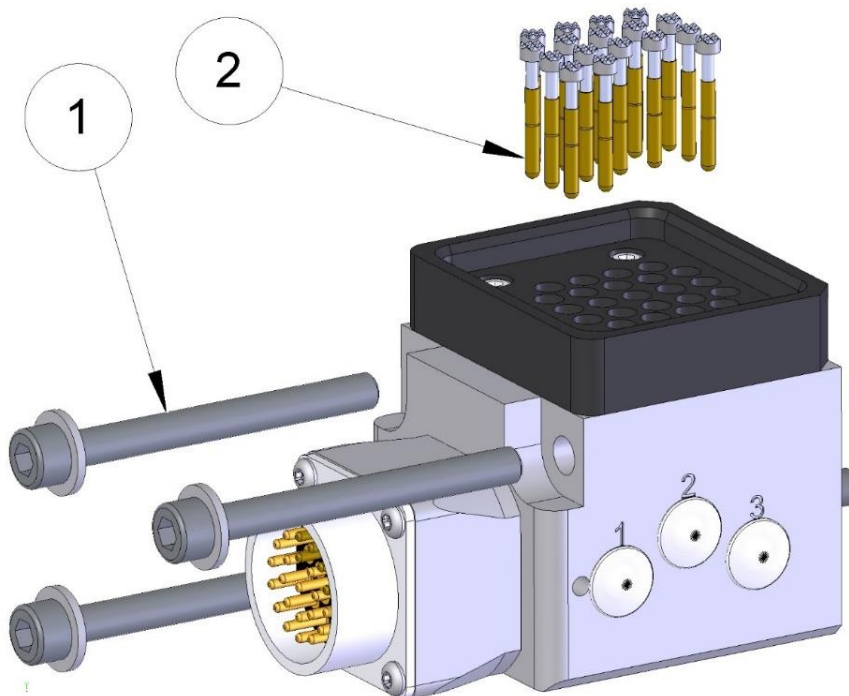

Item	Description	Part number	Wear part	Pcs
1	Mounting screw, M6x60 and washer	21212519-382 and 21512062-153		3
2	Spring-loaded signal pin (P6738-1)	I1287	X	17
2	Spring-loaded signal pin (P7224)	I1287	X	21
2	Spring-loaded signal pin (P6711)	I1287	X	23
2	Spring-loaded signal pin (P6771)	I1287	X	5

12.1.8 Parts list for servo interface M23, P6768-2

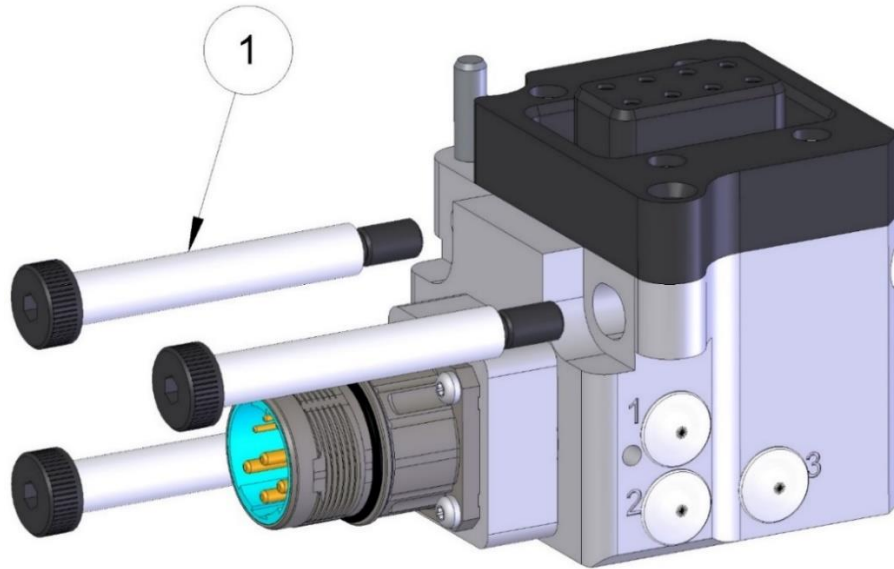

Item	Description	Part number	Wear part	Pcs
1	Shoulder screw 8x50	M6-8x50		3

12.1.9 Parts list for signal interface, P6778, P6780, P7291 and P7289

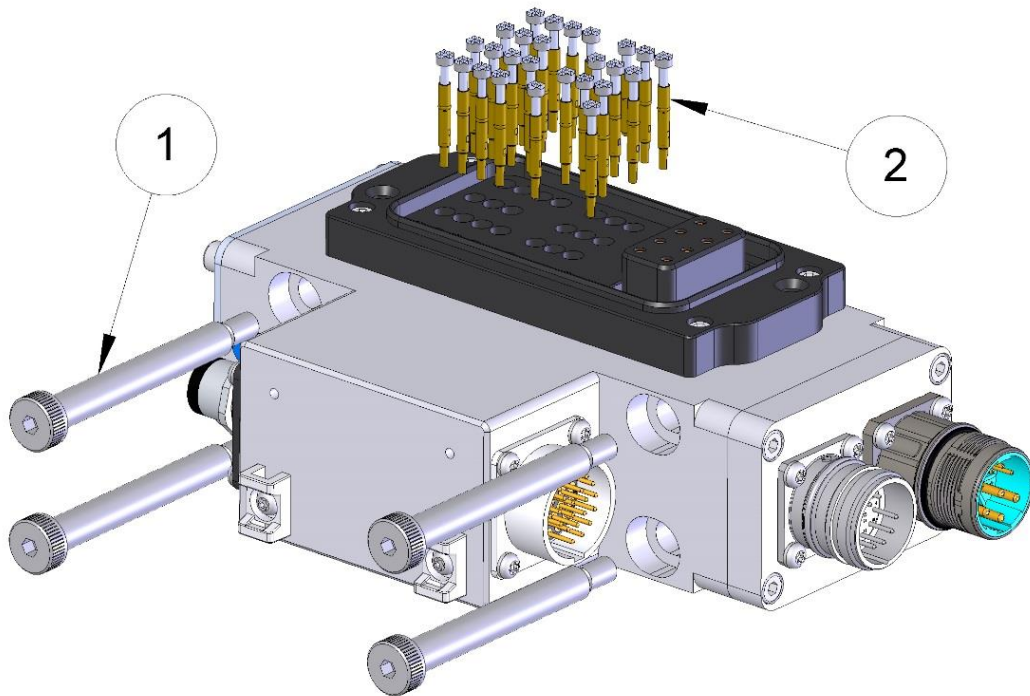

Item	Description	Part number	Wear part	Pcs
1	Shoulder screw 8x60	H 8X60		4
2	Spring-loaded signal pin (P6778)	I1287	X	26
2	Spring-loaded signal pin (P6780)	I1287	X	16
2	Spring-loaded signal pin (P7291)	I1287	X	26
2	Spring-loaded signal pin (P7289)	I1287	X	40

12.1.10 Parts list for signal interface P7325



Item	Description	Part number	Wear part	Pcs
1	Shoulder screw 10x80	H 10X80		3

12.1.11 Parts list for water/air coupling, P7318

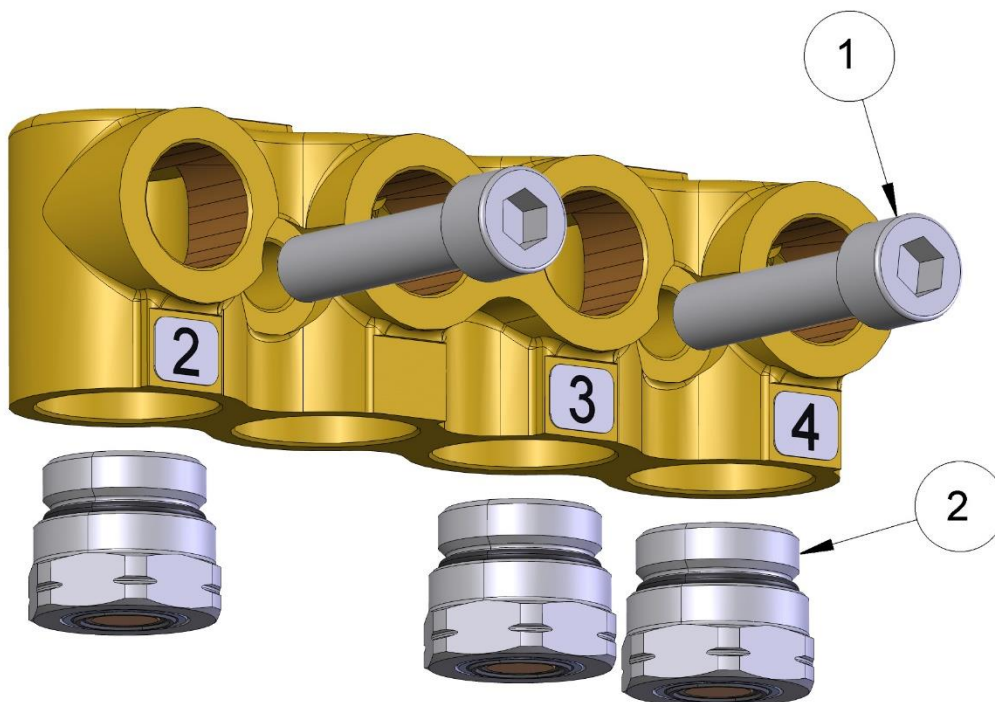

Item	Description	Part number	Wear part	Pcs
1	Mounting screw, M10x45	MC6S 10x45		2
2	Water/air coupling	I1846	X	1-4

12.1.12 Parts list for air coupling, P6847

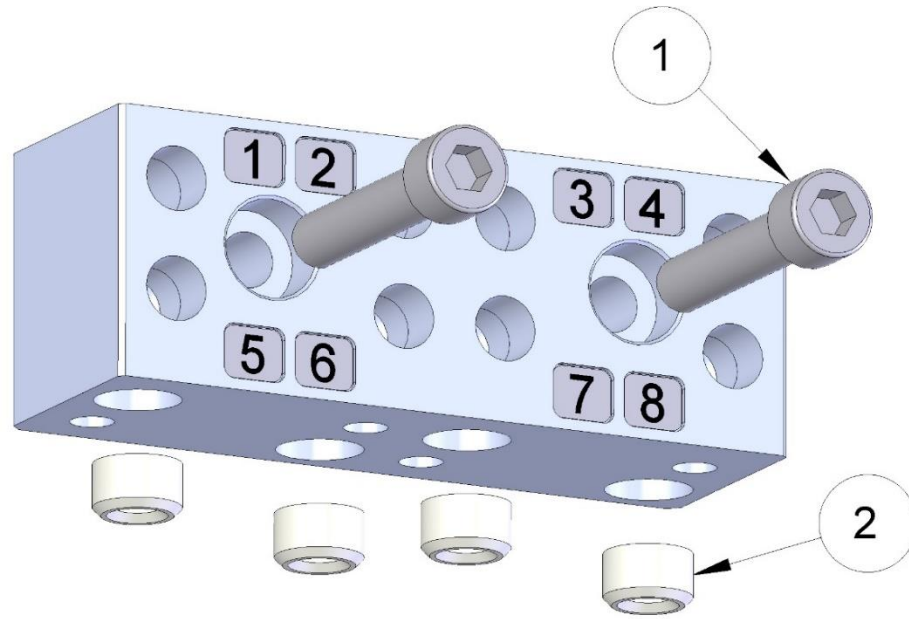

Item	Description	Part number	Wear part	Pcs
1	Mounting screw, M10x50	MC6S 10x50		2
2	Air sealing	63550006-462	X	4

12.1.13 Parts list for weld power connector, P6716, P6784, P6717 and P6794

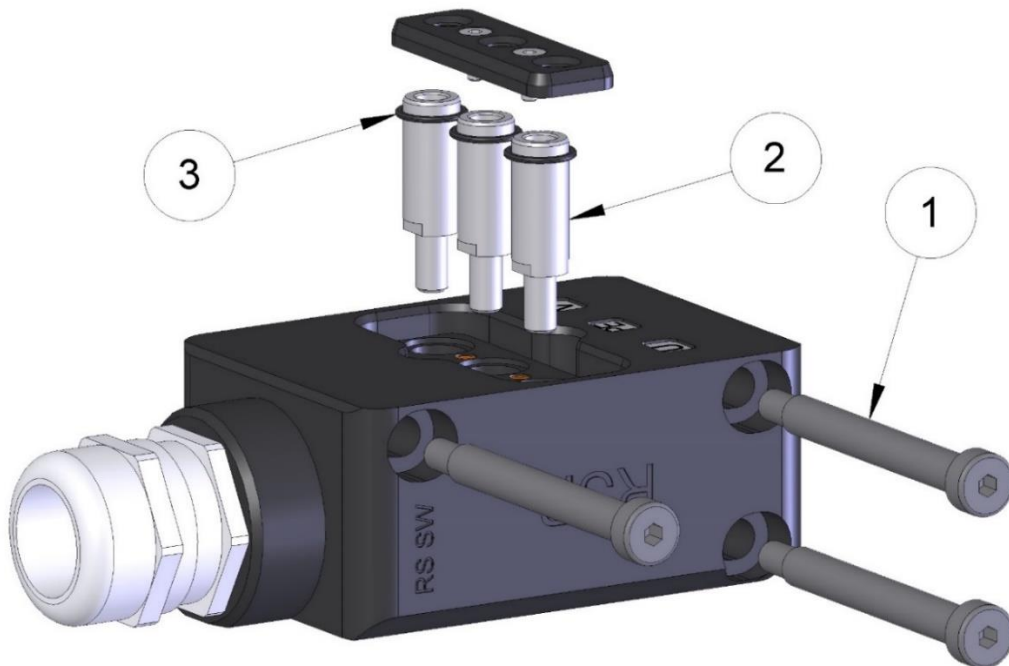

Item	Description	Part number	Wear part	Pcs
1	Shoulder screw 10x80	M8-10x80		3
1	Shoulder screw 10x90 (P6794 only)	M8-10x90		3
2	Weld power socket	I1001	X	3
3	O-ring	I0160		3

12.1.14 Parts list for weld power connector, P6766

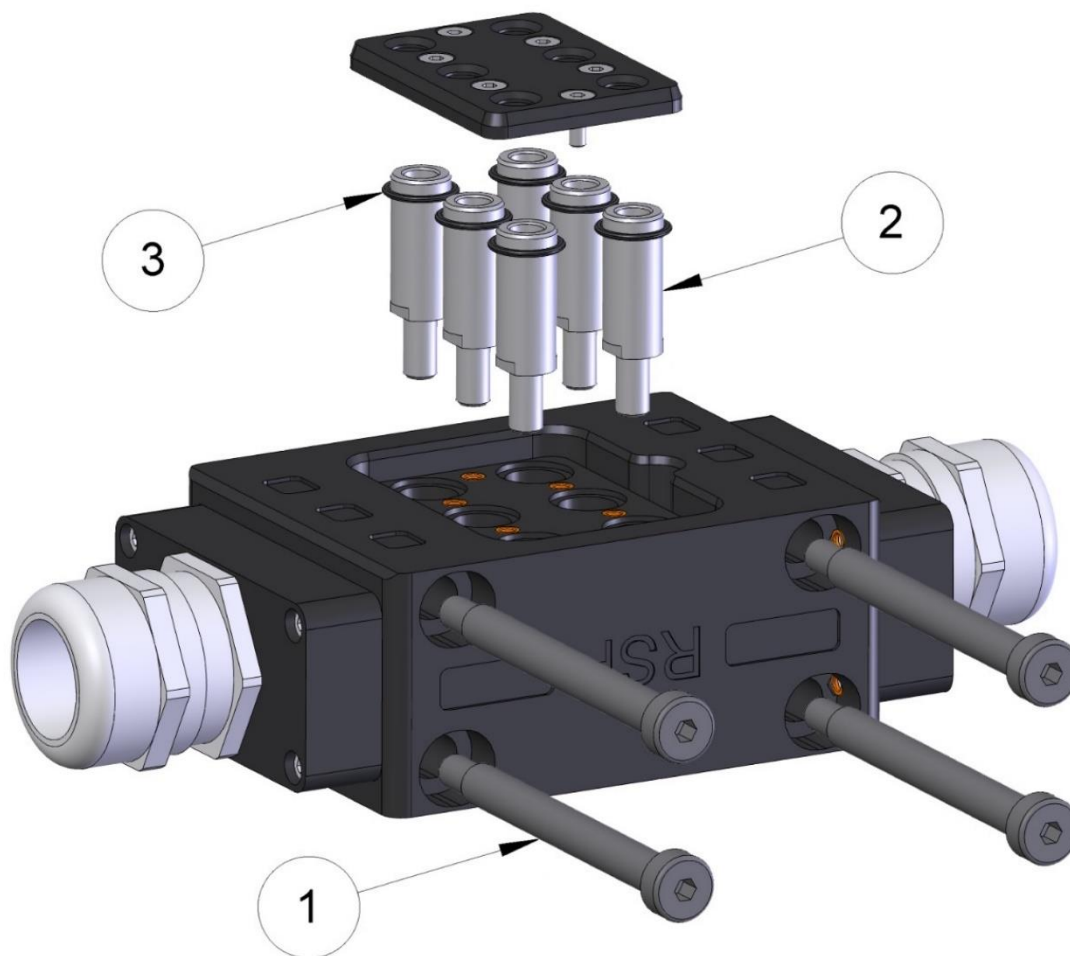

Item	Description	Part number	Wear part	Pcs
1	Shoulder screw 10x90	M8-10x90		4
2	Weld power socket	I1001	X	6
3	O-ring	I0160		6

12.1.15 Parts list for weld power connector, P7336

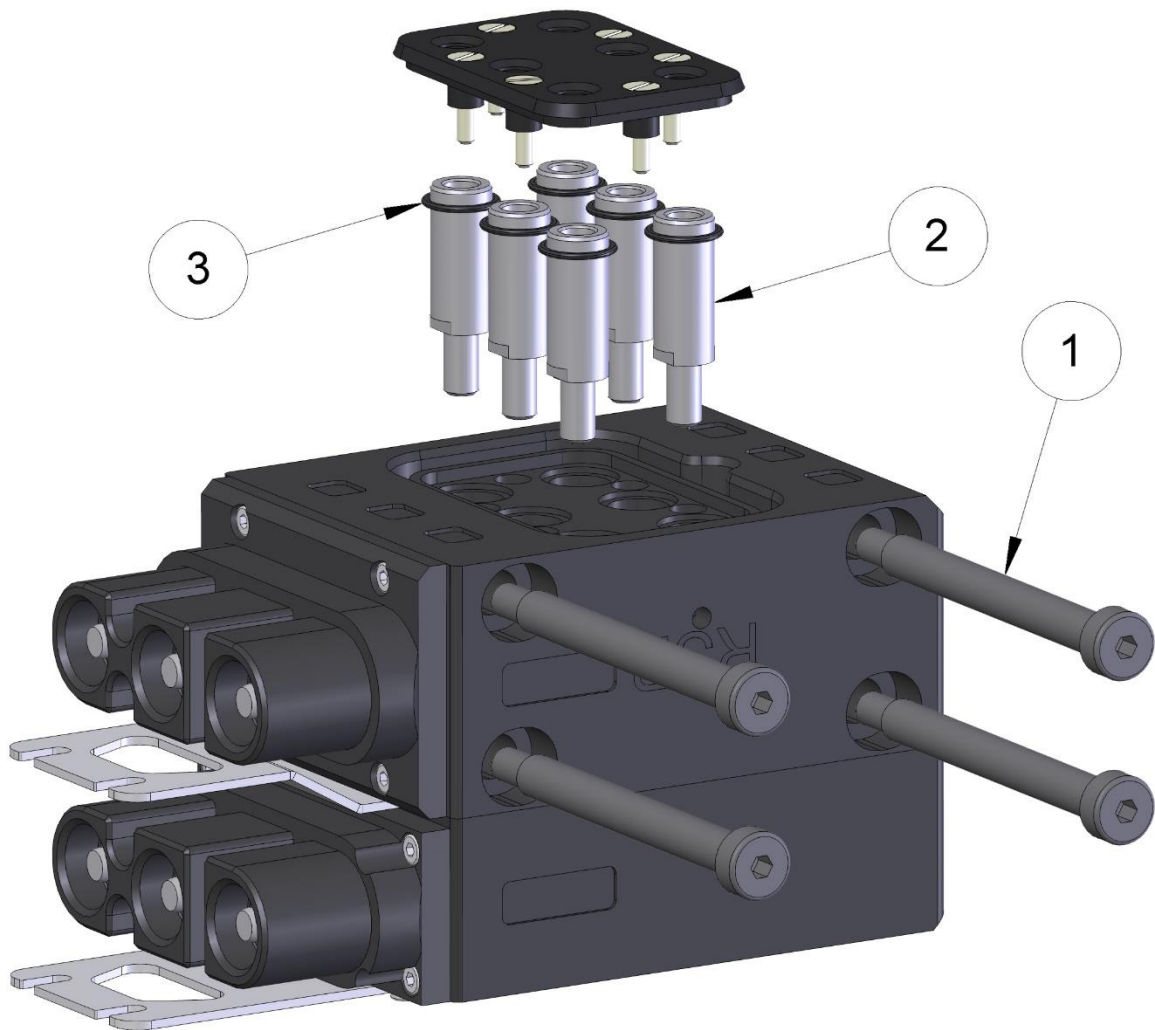

Item	Description	Part number	Wear part	Pcs
1	Shoulder screw 10x90	M8-10x90		4
2	Weld power socket	I1001	X	6
3	O-ring	I0160		6

12.1.16 Parts list for forced opening kit, P6910

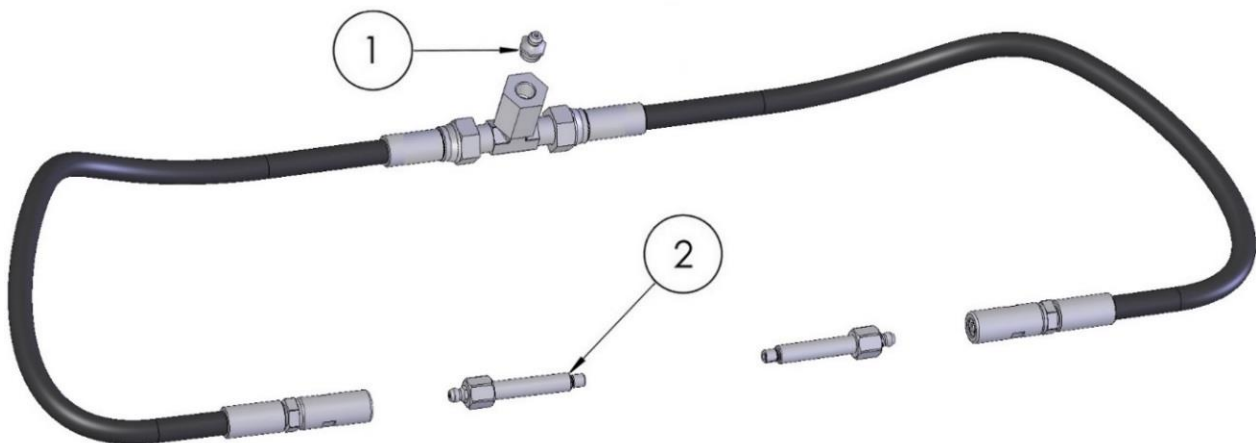

Item	Description	Part number	Wear part	Pcs
1	Nipple	I1335		1
2	Coupling extender	P0178-192		2

12.2 Tool attachment side

12.2.1 Parts list for signal interface, P6739, P7225, P6721 and P6775

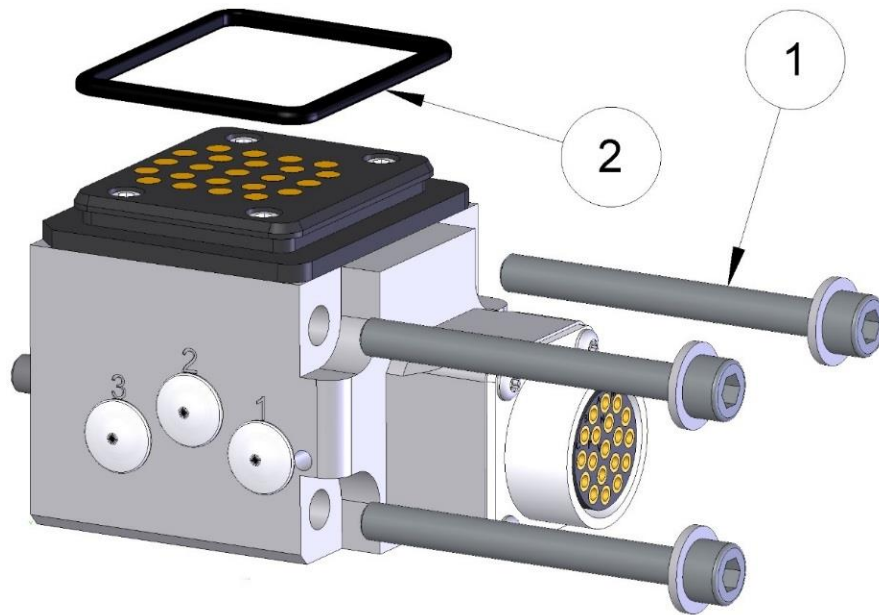

Item	Description	Part number	Wear part	Pcs
1	Mounting screw, M6x60 and washer	21212519-382 and 21512062-153		3
2	O-ring	P0178-349	X	1

12.2.2 Parts list for power interface M23, P6772-2

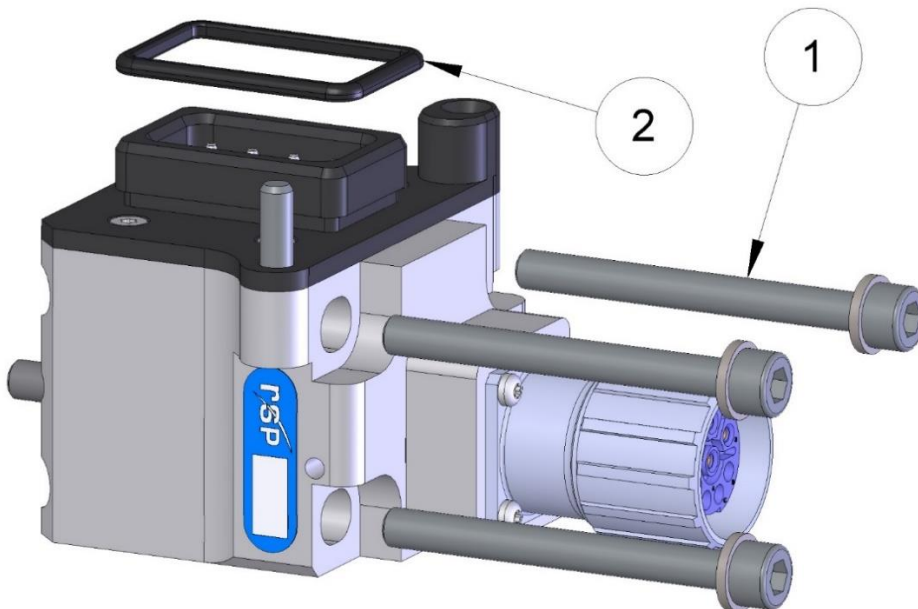

Item	Description	Part number	Wear part	Pcs
1	Mounting screw, M6x60 and washer	21212519-382 and 21512062-153		3
2	O-ring	P0178-350	X	1

12.2.3 Parts list for signal interface, P6779, P6781, P7292 and P7290

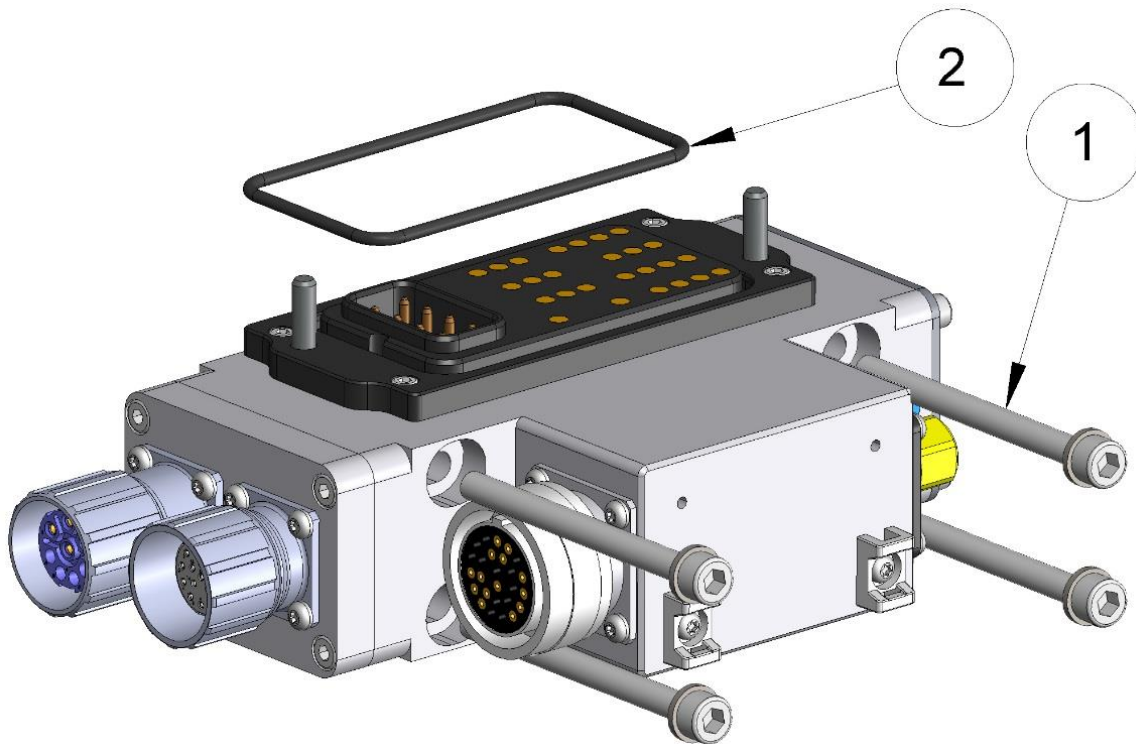

Item	Description	Part number	Wear part	Pcs
1	Mounting screw, M6x70 and washer	21212519-384 and 21512062-153		4
2	O-ring	11048	X	1

12.2.4 Parts list for water/air coupling, P7319

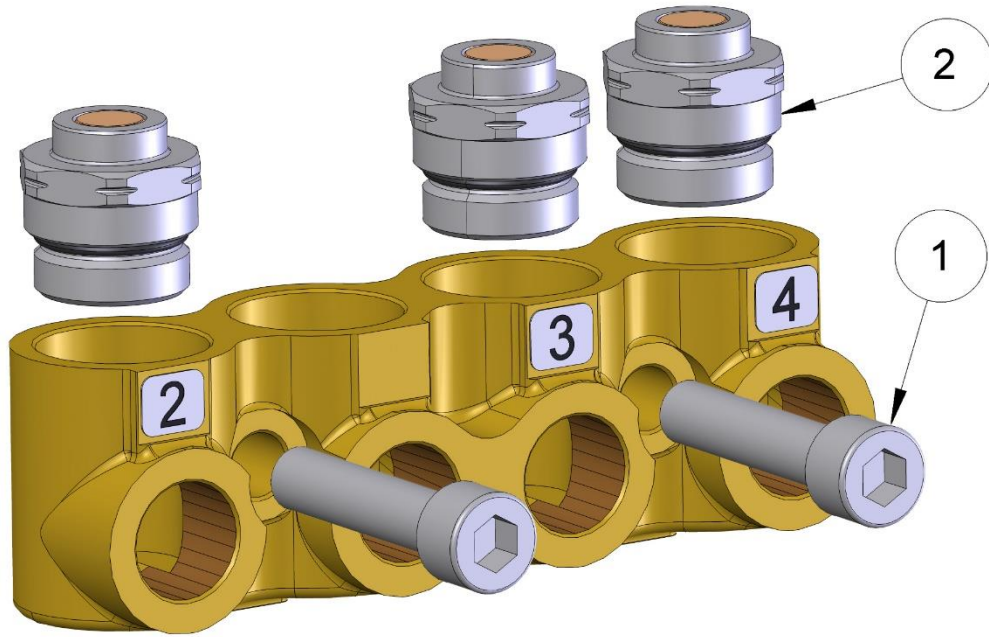

Item	Description	Part number	Wear part	Pcs
1	Mounting screw, M10x45	MC6S 10x45		2
2	Water/air coupling	I1847	X	1-4

12.2.5 Parts list for air coupling, P6848

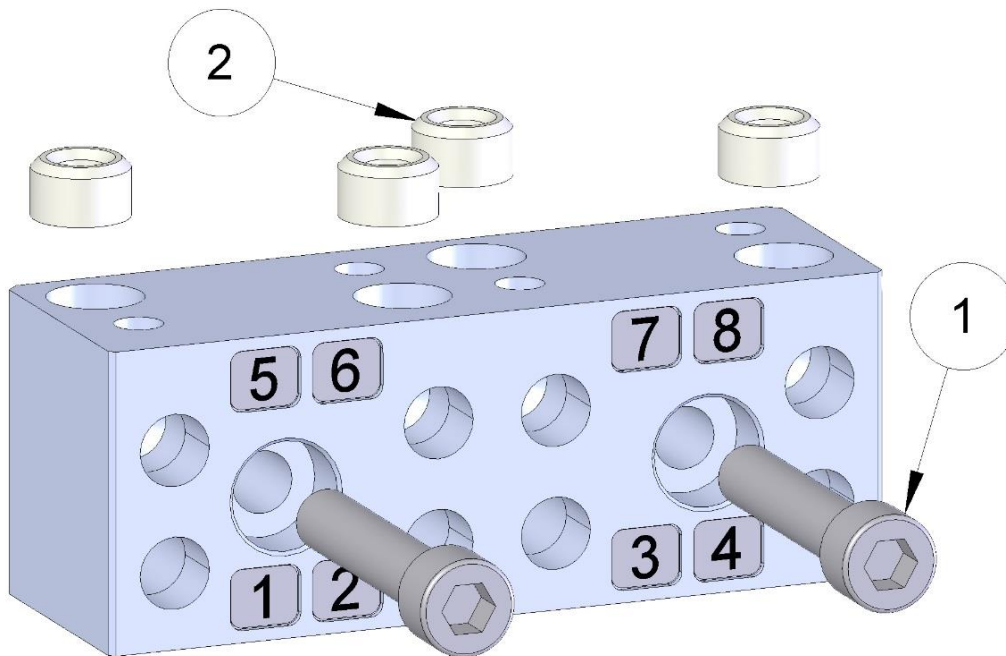

Item	Description	Part number	Wear part	Pcs
1	Mounting screw, M10x50	MC6S 10x50		2
2	Air sealing	63550006-462	X	4

12.2.6 Parts list for weld power connector, P6726

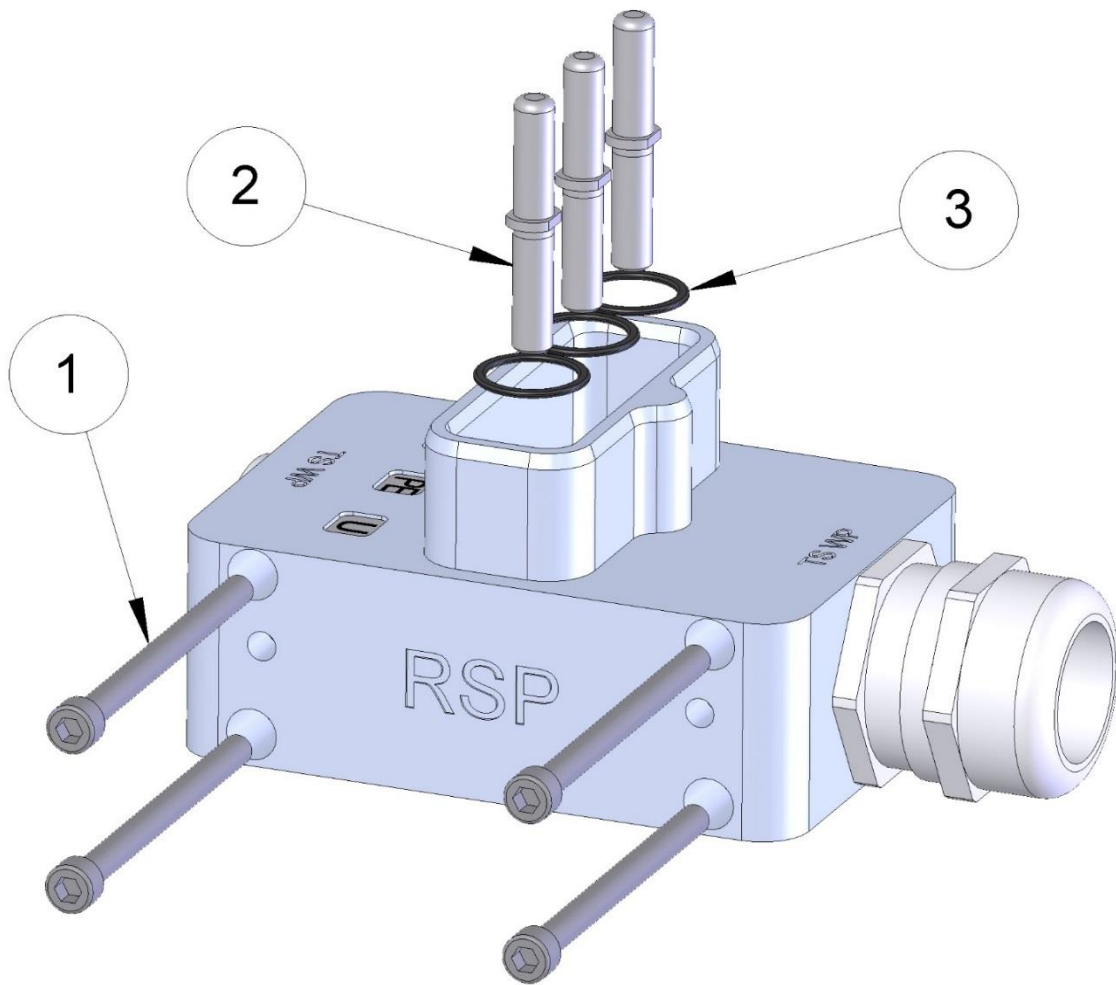

Item	Description	Part number	Wear part	Pcs
1	Mounting screw, M6x80	21212519-386		4
2	Weld power pin	P0230-105	X	3
3	O-ring	I0776		3

